

CHRISTEN *

PRODUCT LETTER

No: 000243

CHRISTEN INDUSTRIES, INC.
1048 SANTA ANA VALLEY ROAD
HOLLISTER, CALIFORNIA 95023
TELEPHONE: (408) 637-7405

By: IC Date: 12-14-81 Page: 1 of 1

Send To: 915 CANOPY KIT

C-0002

C CHRISTEN INDUSTRIES INC.
U 1048 SANTA ANA VALLEY RD.
S HOLLISTER, CA 95023
T

Subject: 31223-501 REAR HINGE
ASSEMBLY INSPECTION

There is a possibility that the 31223-501 rear hinge assembly supplied in your 915 Canopy Kit may have been manufactured incorrectly with the hinge bushing located at an incorrect distance from the bracket which mounts the coupling plate shafts.

The enclosed Engineering Sketch X-90138 illustrates the nominal dimensions between the hinge bushing and the nearest hole in the bracket. When checking the measurement, it is important that the working surface is smooth and flat and that downward pressure is applied to the edge of the bracket on the side where the measurement is taken.

If the indicated measurement is not within the dimensional tolerance allowed, telephone the Christen factory collect to request a replacement part.

No action is required if the rear hinge assembly has been installed and fits properly with the canopy frame and allows normal canopy opening and ejection operations.

Enclosures:

1 ea Engineering Sketch X-90138

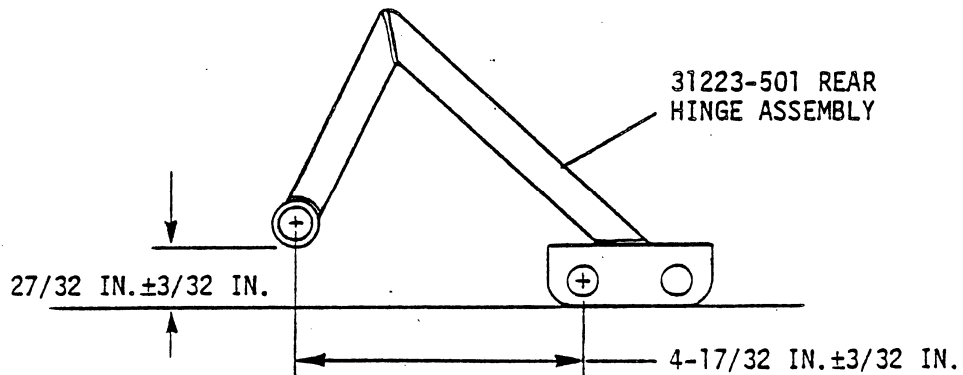
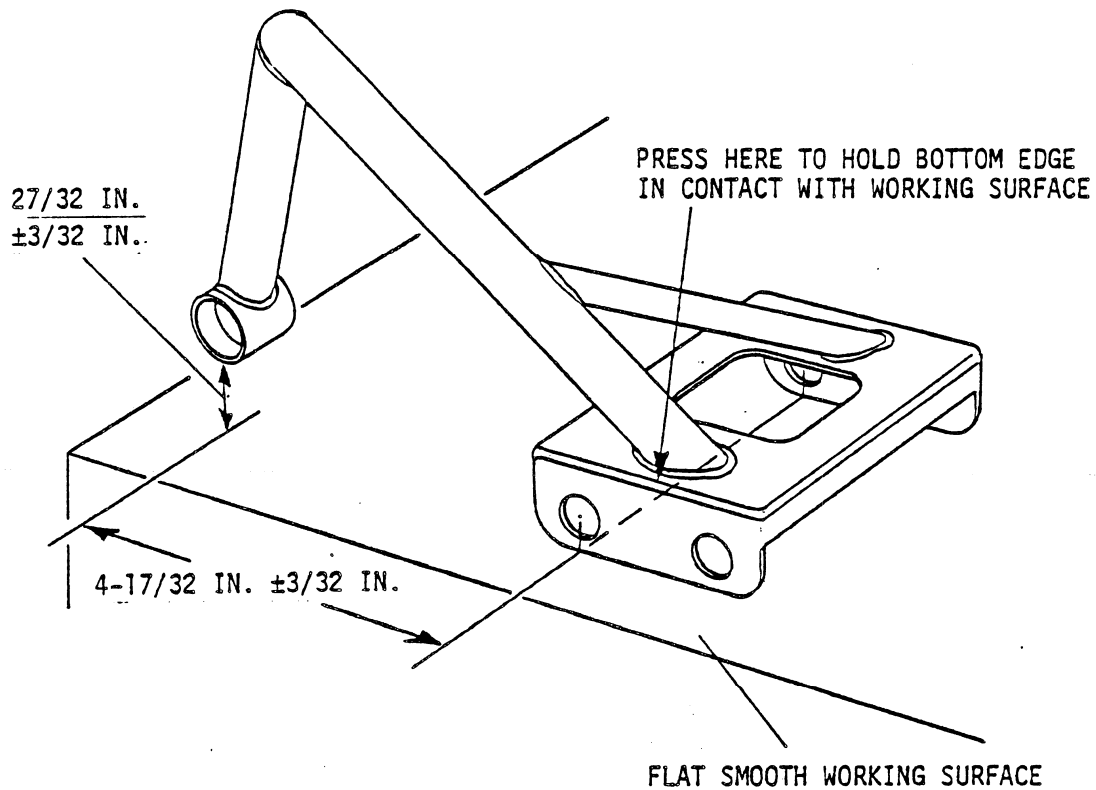

SIDE VIEW

UNLESS OTHERWISE SPECIFIED: TOLERANCES: FRAC. ± 1/64 DEC. XXX ± .005 ANGLES ± 0° 30' DIMENSIONS IN INCHES DO NOT SCALE DRAWING	MATERIAL AND CONDITION			CHRISTEN  CHRISTEN INDUSTRIES HOLLISTER, CALIFORNIA		
	NOTED					
	FINISH			TITLE CANOPY REAR HINGE INSPECTION		
	NONE					
DRAWN BY	DATE	PROJECT	CODE	NO.	ISSUE	
I. CLEDE	12-1-81	EAGLE II AIRCRAFT	PA	X- 90138		
APPROVED BY	DATE					