

No: 000255

CHRISTEN INDUSTRIES, INC.
1048 SANTA ANA VALLEY ROAD
HOLLISTER, CALIFORNIA 95023
TELEPHONE: (408) 637-7405

By: FLC Date: 02-27-82 Page: 1 of 1

Send To: 902 LOWER WING KIT

C ** AFFIX LABEL HERE **

U
S
TSubject: CLARIFICATION OF WOOD
GRAIN DESCRIPTION IN
PREVIOUS PRODUCT LETTER
000252 DATED 02-16-82

The subject product letter requested inspection of the direction of wood grain on the tierod blocks located on the rear spars of the upper and lower wings of the Eagle II aircraft. The phrase "perpendicular to the spar face" has caused much confusion. In response to many telephone calls requesting clarification of the grain direction requirement we have prepared Engineering Sketch X-90147 which illustrates the correct and incorrect grain directions.

It is unlikely that any blocks with incorrect grain were supplied to any Eagle builder, but one incorrect block was found on a Christen factory demonstrator aircraft, and this requires that inspection of the blocks be performed on all kits and completed aircraft.

ENCLOSURES: Engineering Sketch X-90147

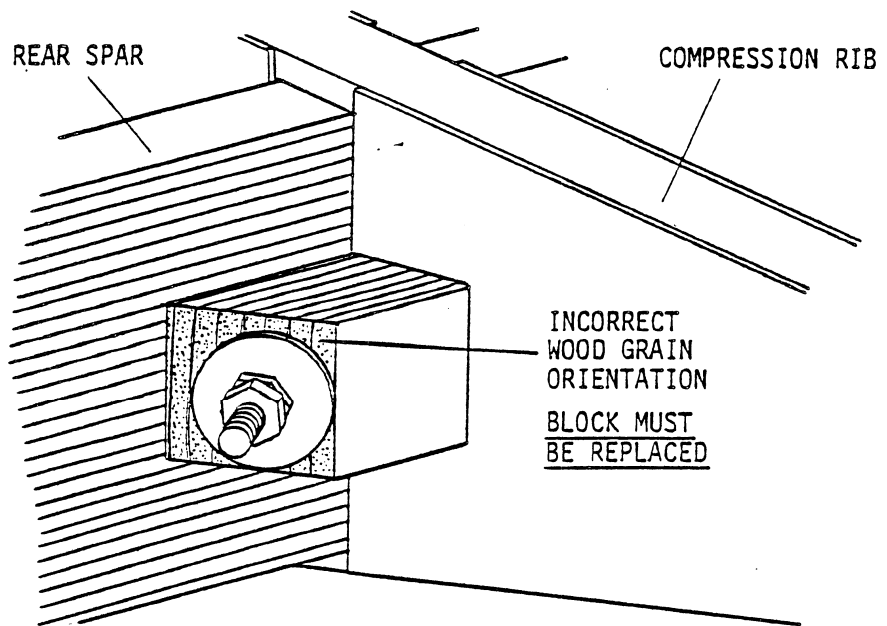
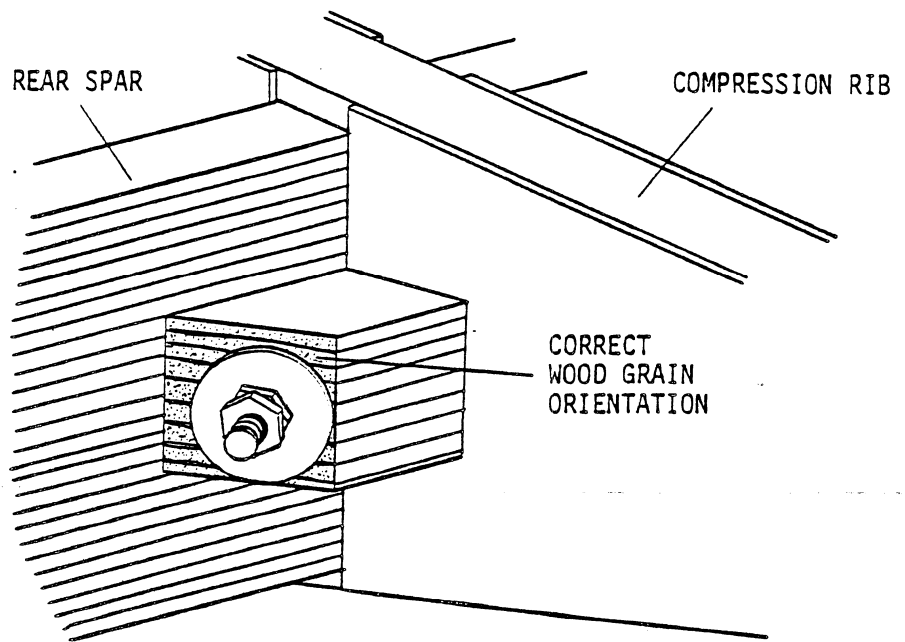

UNLESS OTHERWISE SPECIFIED: TOLERANCES: FRAC. \pm 1/64 DEC. XXX \pm .005 ANGLES \pm 0° 30' DIMENSIONS IN INCHES DO NOT SCALE DRAWING	MATERIAL AND CONDITION NOTED			 CHRISTEN INDUSTRIES HOLLISTER, CALIFORNIA		
	FINISH NONE					
	DRAWN BY I. CLEDE	DATE 2-25-82	PROJECT EAGLE II AIRCRAFT		TITLE TIEROD BLOCK INSPECTION	
	APPROVED BY	DATE			CODE PA	NO. X-90147