

No: 000305

CHRISTEN INDUSTRIES, INC.  
1048 SANTA ANA VALLEY ROAD  
HOLLISTER, CALIFORNIA 95023  
TELEPHONE: (408) 637-7405

By: FLC Date: 05-04-83 Page: 1 of 1

Send To: 915 CANOPY KIT

C \*\* AFFIX LABEL HERE \*\*

U  
S  
TSubject: ADDITION OF HYDRAULIC  
SNUBBER TO 915 CANOPY  
KIT ON EAGLE II AIRCRAFT

A telescoping brace with hydraulic snubbing motion has been developed for the canopy system on the Eagle II aircraft. The attached copy of Engineering Sketch X-90158 depicts the brace installation.

The brace supports the canopy assembly in the open position to allow taxiing of the Eagle II aircraft on rough terrain or in strong winds without risk of damage to the canopy support arms or bearing assemblies. It telescopes freely when the canopy is drawn closed, but it extends slowly against the hydraulic snubbing action, regardless of opening force, when the canopy is opened. If the canopy is released when partially opened, it will extend slowly to the full open position under the force of its own weight only. The brace also provides slight snubbing action during closing and on the initial pull-back of the canopy for opening.

All components of the system are precision machined aluminum, bronze, or stainless steel with satin black corrosion resistant finish. The complete system weighs less than one pound and it can be installed with only hand tools in about one hour.

The brace system is now available for retrofit installation to canopy systems previously shipped or currently on order. It will be a standard part of the 915 Canopy Kit in the future beginning with serial 0262 with appropriate adjustment of price.

All Eagle II owners and builders should install the snubbing brace on their aircraft to improve canopy performance and to eliminate the risk of damage or misalignment of canopy components which can result from overloading the canopy support system when the brace is not installed.

915-SN CANOPY SNUBBER KIT  
UPS shipping charge

Enclosures:

ENGINEERING SKETCH X-90158

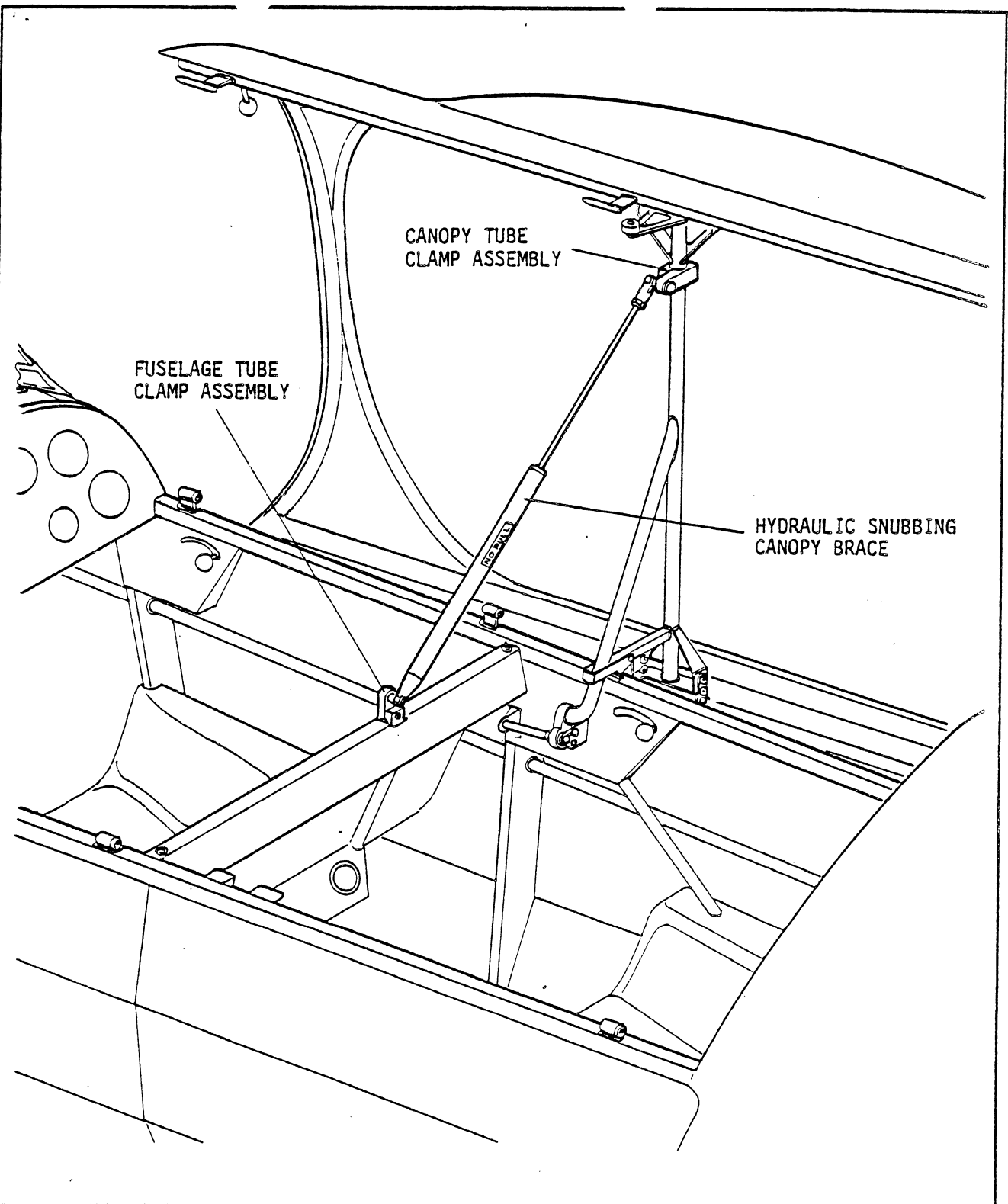

CANOPY TUBE CLAMP ASSEMBLY

FUSELAGE TUBE CLAMP ASSEMBLY

HYDRAULIC SNUBBING CANOPY BRACE

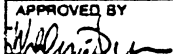
<b>UNLESS OTHERWISE SPECIFIED:</b>  <b>TOLERANCES:</b> FRAC. $\pm$ 1/64 DEC. XXX $\pm$ .005 ANGLES $\pm$ 0° 30'  DIMENSIONS IN INCHES  DO NOT SCALE DRAWING	<b>MATERIAL AND CONDITION</b> NOTED		<b>CHRISTEN</b>  <small>CHRISTEN INDUSTRIES HOLLISTER, CALIFORNIA</small>		
	<b>FINISH</b> NONE		<b>ENGINEERING SKETCH</b>		
	<b>DRAWN BY</b> I. CLEDE	<b>DATE</b> 4-24-83	<b>PROJECT</b> EAGLE II AIRCRAFT	<b>TITLE</b> 915-SN CANOPY SNUBBER KIT	
	<b>APPROVED BY</b> 	<b>DATE</b> 4-25-83		<b>CODE</b> PA	<b>NO.</b> X-90158
				<b>ISSUE</b>	