

PITTS S-2B

PARTS CATALOG

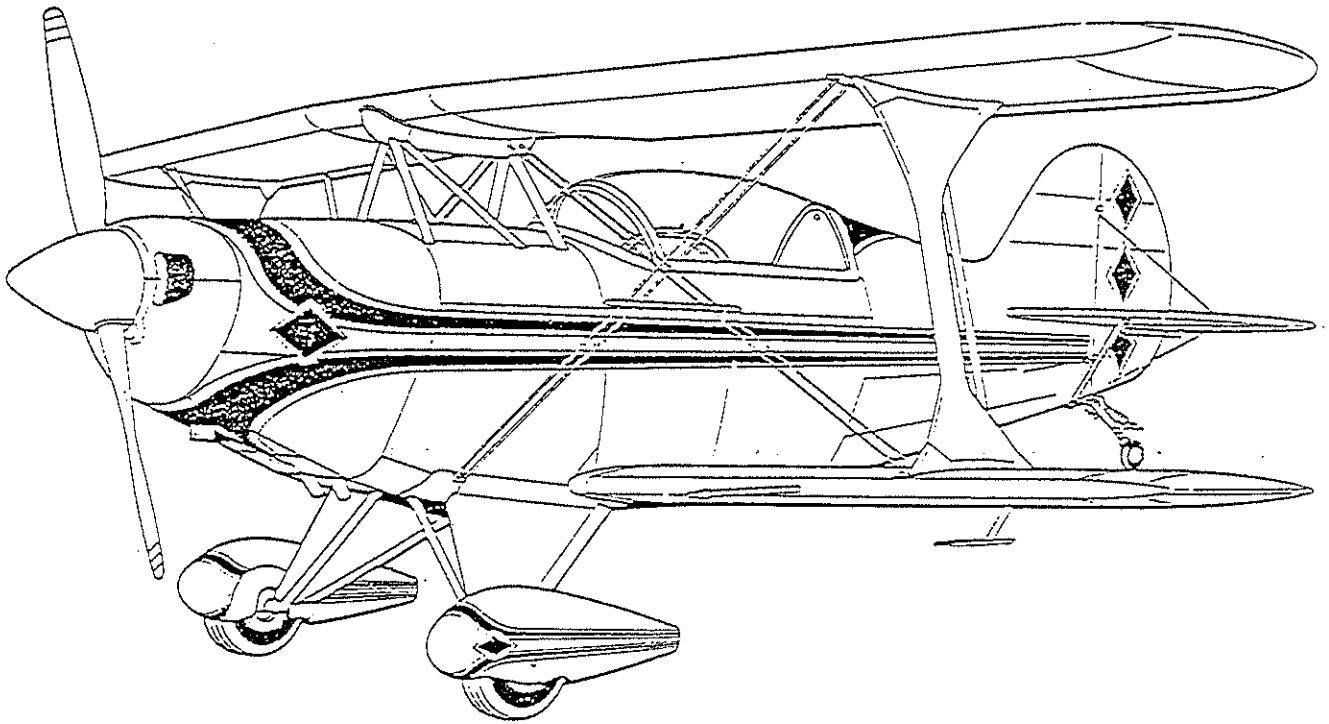

AVIAT AIRCRAFT INC.

P.O. Box 1240
672 South Washington
Afton, WY 83110
307-885-3151
facsimile: 307-885-9674
e-mail: aviat@aviataircraft.com



This page
intentionally blank.

Table Of Contents

General Information

- Figure 1: Wing Installation
 - Figure 2: Lower Wing Assembly
 - Figure 3: Upper Wing Assembly
 - Figure 4: Aileron Assembly
 - Figure 5: Fuselage Structure
 - Figure 6: Fuselage Tabs & Brackets
 - Figure 7: Fuselage Fairings
 - Figure 8: Covered Fuselage
 - Figure 9: Seat & Floorboard Installation
 - Figure 10: Tail Surfaces Installation
 - Figure 11: Tail Surfaces Assembly
 - Figure 12: Landing Gear Installation
 - Figure 13: Engine Installation
 - Figure 14: Engine Baffles
 - Figure 15: Cowling Installation
 - Figure 16: Oil System Installation
 - Figure 17: Fuel System Installation
 - Figure 18: Instruments & Placards
 - Figure 19: Trim Control System
 - Figure 20: Elevator Control System
 - Figure 21: Aileron Control System
 - Figure 22: Rudder Control System
 - Figure 23: Electrical System
 - Figure 24: Canopy Installation
-

This page
intentionally blank.

General Information

Introduction

This catalog provides information for identifying and ordering replacement parts for the Pitts S-2B aircraft.

The Parts Catalog is organized in twenty-four related parts groups, each with a single illustration figure. The figure identifies each replacement part with an item number. The parts are described in detail in the tabulation accompanying each figure.

The Parts Catalog presents parts in order of item number. Following each item number is the Christen part number or code number, an abbreviated description or AN number, the quantity required for the parts group illustrated, and the aircraft serial numbers affected by this item number.

Precautions

Repairs to any type-certificated (production) aircraft must be performed by, or directly supervised by, an FAA certificated A&P or AI mechanic. Care is required in selecting any replacement parts because some parts may require special installation procedures (such as welding, critical alignment, or trimming to fit). Also, some parts may require installation using additional materials (such as lubricants or adhesives).

Ordering Information

Include with each item ordered (a) the Christen part number or code number and (b) the part description or AN number. If the part number is not known, include a complete description of the part, its function, and its location on the aircraft.

Postage-paid order forms are available on request. Shipments are normally made by United Parcel Service or by motor freight for large items. Place all orders with the nearest Christen dealer or directly with the Christen factory at the following address:

P.O. Box 1240
672 South Washington
Afton, WY 83110
307-886-3151
facsimile 307-886-9674
e-mail: AVIAT @ ssa.com

This page
intentionally blank.

FIGURE 1
WING INSTALLATION

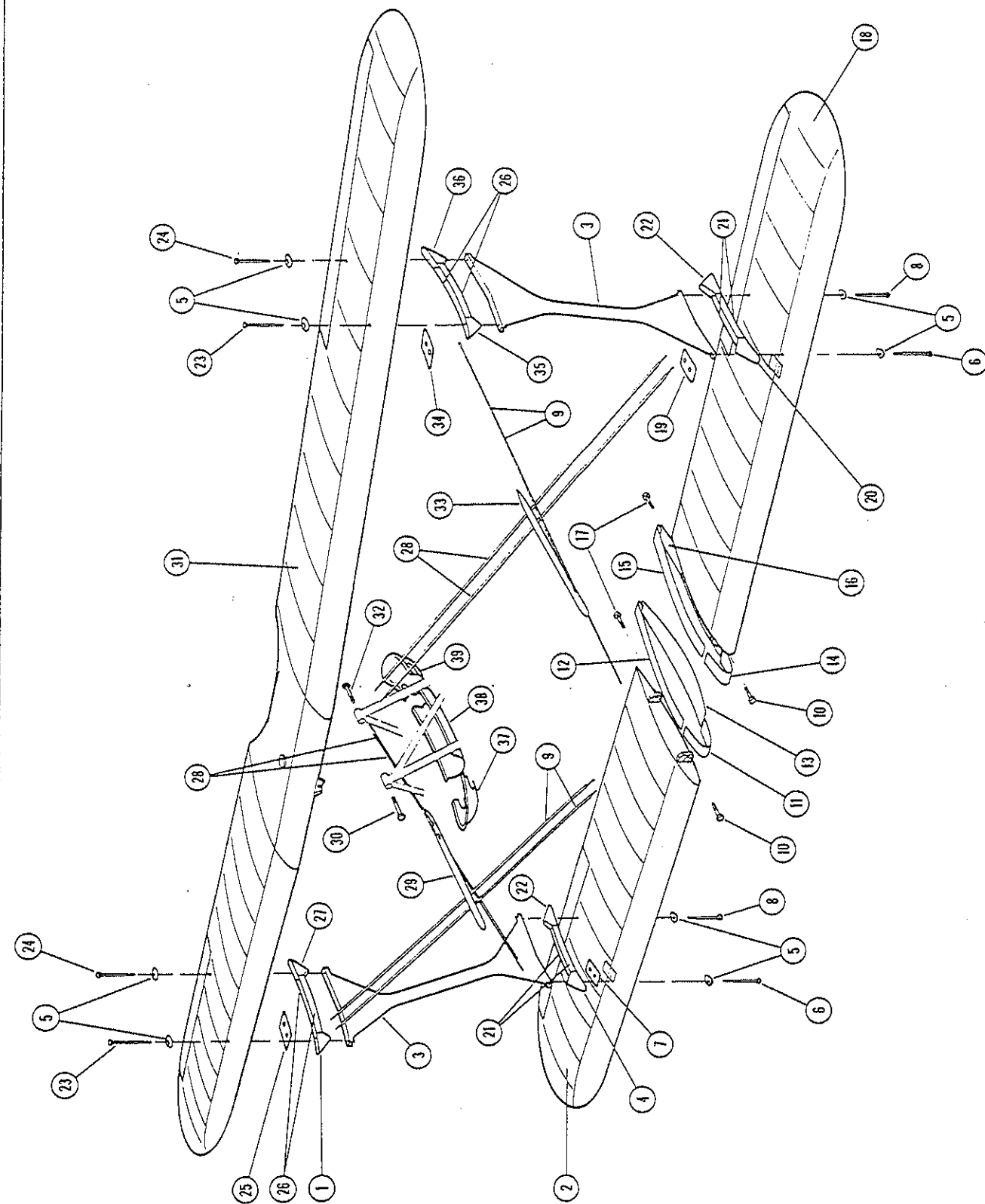

FIGURE 1: WING INSTALLATION

FIGURE 1: WING INSTALLATION

ITEM	PART NUMBER	DESCRIPTION	QTY	SERIAL NO'S AFFECTED
1	2-1003-004	Fairing, I-Strut (upper right wing)	1	
2	2-4300-060	Lower Right Hand Wing (completed uncovered)	1	
	2-4300-550	Lower Right Hand Wing (covered thru silver)	1	
	2-4300-560	Lower Right Hand Wing (covered and painted)	1	
3	2-4143-001	Weidment, I-Strut	2	
4	2-1003-010	Fairing, I-Strut (lower right wing)	1	
5	58860	Washer: AN 970-4	16	
6	51471	Bolt: AN4-50A	2	
	55400	Nut: AN365-428A	2	
	58760	Washer: AN960-416	2	
7	2-1003-042	Fairing, Landing Wire R H	1	
8	51450	Bolt: AN4-40A	2	
	55400	Nut: AN365-428A	2	
	58760	Washer: AN960-416 (as required)	-	
9	57040	Tie Rod, 81" Type II Streamlined: AN675C	4	
10	51802	Bolt: AN5-22A	2	
	55425	Nut: AN365-524A	2	
	58780	Washer: AN960-516	6	
11	2-1003-016	Fairing, Forward Root, R H	1	
12	2-1003-018	Fairing, Lower Wing Root, Upper R H	1	
13	2-1003-020	Fairing, Wing Root R H	1	
14	2-1003-015	Fairing, Forward Root L H	1	
15	2-1003-017	Fairing, Lower Wing Root, Upper L H	1	
16	2-1003-019	Fairing, Wing Root L H	1	
17	51076	Bolt: AN4-16A	2	
	55400	Nut: AN365-428A	2	
	58760	Washer: AN960-416	4	
18	2-4300-059	Lower Left Hand Wing (completed uncovered)	1	
	2-4300-549	Lower Left Hand Wing (completed thru silver)	1	
	2-4300-559	Lower Left Hand Wing (covered and painted)	1	
19	2-1003-041	Fairing, Landing Wire L H	1	
20	2-1003-009	Fairing, I-Strut (lower left wing)	1	
21	2-1003-011	Fairing, I-Strut (lower wing)	4	
22	2-1003-005	Fairing, I-Strut (lower left wing)	1	
23	2-1003-006	Fairing, I-Strut (lower right wing)	1	
	51514	Bolt: AN4-53A	2	
	55400	Nut: AN365-428A	2	
24	58760	Washer: AN960-416	2	
	51461	Bolt: AN4-45A	2	
	55400	Nut: AN365-428A	2	
	58760	Washer: AN960-416 (as required)	-	
25	2-1003-040	Fairing, Flying Wire R H	1	
26	2-1003-012	Fairing, I-Strut (upper wing)	4	
27	2-1003-008	Fairing, I-Strut (upper right wing)	1	
28	57030	Tie Rod, 84" Type II Streamlined: AN675C	4	
29	2-4102-002	Separator, R H	1	
30	51976	Bolt: AN5-30A	1	
	55425	Nut: AN365-524A	1	
	58780	Washer: AN960-516	2	
31	2-4100-001	Upper Wing Assembly (completed uncovered)	1	
	2-4100-501	Upper Wing Assembly (covered thru silver)	1	
	2-4100-511	Upper Wing Assembly (covered and painted)	1	
32	52601	Bolt: AN6-32A	1	
	55450	Nut: AN365-624A	1	
	58790	Washer: AN960-616	2	
33	2-4102-001	Separator, L H	1	

FIGURE 1: WING INSTALLATION

ITEM	PART NUMBER	DESCRIPTION	QTY	SERIAL NO.'S AFFECTED
34	2-1003-039	Fairing, Flying Wire L H	1	
35	2-1003-004	Fairing, I-Strut, (upper left wing)	1	
36	2-1003-007	Fairing, I-Strut, (upper left wing)	1	
37	2-1003-053	Fairing, Forward Cabane	1	
38	2-1003-054	Fairing, Center Cabane	1	
39	2-1003-055	Fairing, Aft Cabane	1	
	2-1003-057	Cover Plate L H (left wing, not shown)	1	
	2-1003-058	Cover Plate R H (right wing, not shown)	1	
	59160	Screw: 4 x 3/8 PK	32	



FIGURE 2
LOWER WING ASSEMBLY



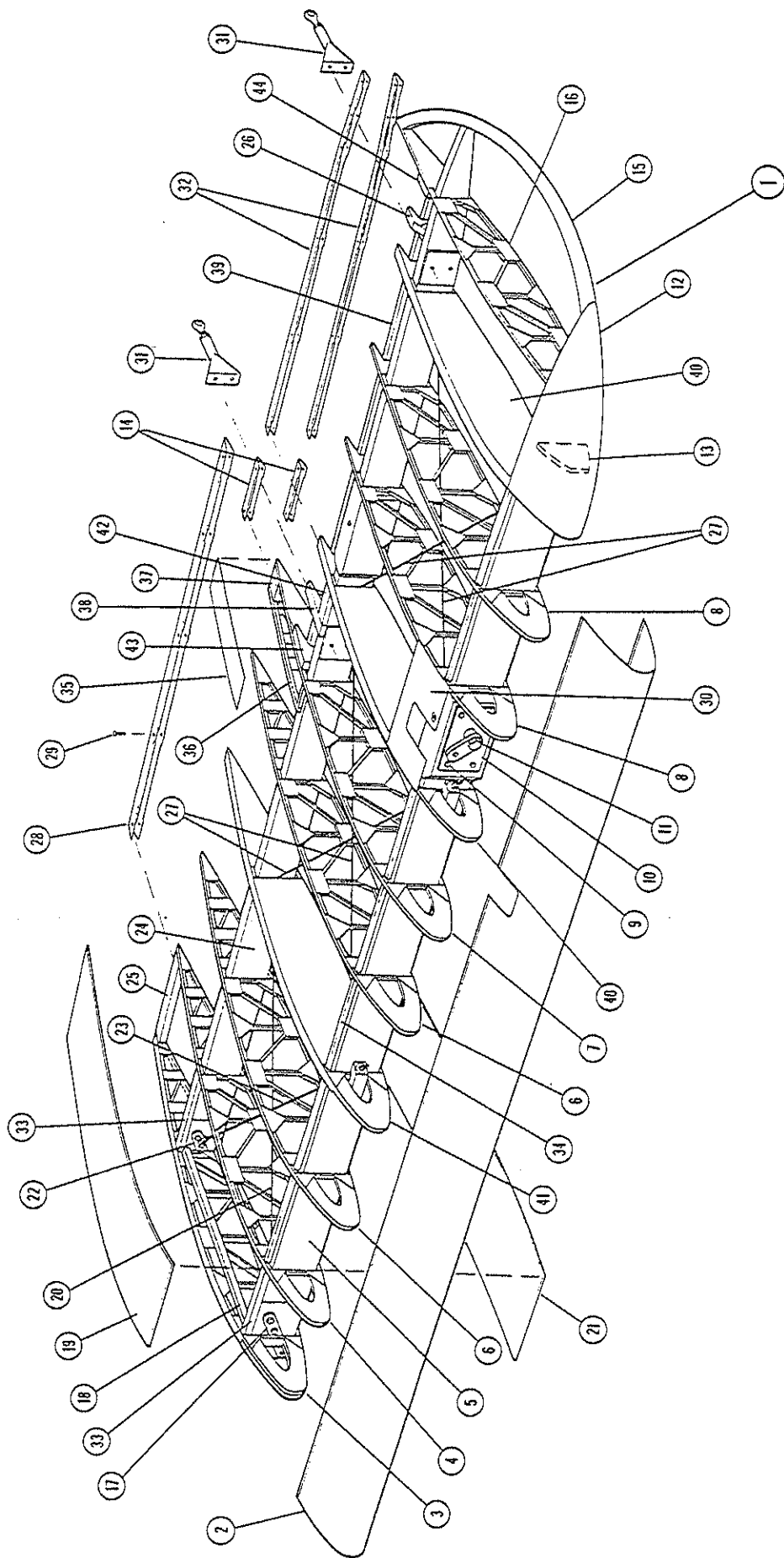

FIGURE 2: LOWER WING ASSEMBLY

FIGURE 2: LOWER WING ASSEMBLY

ITEM	PART NUMBER	DESCRIPTION	QTY	SERIAL NO.'S AFFECTED
1	2-4300-059	Lower Wing Assembly (left wing)	1	
	2-4300-060	Lower Wing Assembly (right wing)	1	
2	77018	Leading Edge	2	
3	2-4305-031	Rib, Lower Wing Butt L H	1	
	2-4305-032	Rib, Lower Wing Butt R H	1	
4	2-4307-000	Rib, Lower Wing (station 7.00)	2	
5	2-4300-001	Spar, Lower Front L H	1	
	2-4300-002	Spar, Lower Front R H	1	
6	2-4309-000	Rib, Lower Wing (station 17.50 & 35.50)	4	
7	2-4311-001	Rib, Lower Wing L H (station 44.50, left wing)	1	
	2-4311-002	Rib, Lower Wing R H (station 44.50, right wing)	1	
8	2-4313-001	Rib, Lower Wing (station 63.50 & 71.50)	4	
9	51251	Bolt: AN4-24A	8	
	55400	Nut: AN365-428A	8	
	58760	Washer: AN960-416	16	
10	2-4321-000	Plate, Spar Reinforcement	4	
11	2-4323-001	Bushing	2	
	2-4323-002	Bushing	4	
	2-4322-001	Lug, Landing Wire	4	
	53051	Bolt: AN8-42A	2	
	55526	Nut: AN365-820A	2	
	58805	Washer: AN960-816	6	
12	2-4100-037	Wing Tip, Fiberglass	2	
13	2-4300-013	Rib, Lower Wing Leading Edge	2	
14	2-4120-032	Trailing Edge, Wing	4	
15	2-4118-000	Bow, Wing Tip	2	
16	2-4317-023	Rib, Lower Wing Tip L H	1	
	2-4317-024	Rib, Lower Wing Tip R H	1	
17	2-4319-001	Fitting, Lower Wing	4	
	51151	Bolt: AN4-20A	4	
	55400	Nut: AN365-428A	6	
	58760	Washer: AN960-416	18	
	2-4325-000	Lug, Drag Wire	2	
	51176	Bolt: AN4-21A	2	
18	2-4300-012	Member, Compression	4	
19	2-4300-010	Walk, Wing	2	
20	76105	Drag Wire, 31"	2	
	54548	Nut: AN315-3	4	
	56940	Terminal: AN665-21R	2	
	50026	Bolt: AN3-5A	2	
	55392	Nut: AN365-1032C	2	
	58740	Washer: AN960-10	2	
	58850	Washer: AN970-3	2	
21	2-4300-011	Skin, Bottom	2	
22	2-4318-001	Fitting, Lower Wing	4	
	51026	Bolt: AN4-14A	4	
	55400	Nut: AN365-428A	6	
	58760	Washer: AN960-416	18	
	2-4325-000	Lug, Drag Wire	2	
	51051	Bolt: AN4-15A	2	
23	76106	Drag Wire, 32"	2	
	54548	Nut: AN315-3	4	
	56940	Terminal: AN665-21R	2	
	58850	Washer: AN970-3	2	
	50026	Bolt: AN3-5A	2	
	55392	Nut: AN365-1032C	2	

FIGURE 2- LOWER WING ASSEMBLY

ITEM	PART NUMBER	DESCRIPTION	QTY	SERIAL NO.'S AFFECTED
	58740	Washer: AN960-10	2	
24	2-4300-003	Spar, Rear Lower L H	1	
	2-4300-004	Spar, Rear Lower R H	1	
25	2-4300-041	Wedge	2	
26	2-4300-061	Block, Cove	2	
27	76107	Drag Wire, 38 1/2"	8	
	58850	Washer: AN970-3	16	
	54548	Nut: AN315-3	32	
28	2-4120-031	Trailing Edge, Wing	2	
29	56408	Rivet: AN470A3-8	24	
30	2-4314-003	Plate, Access L H	1	
	2-4314-010	Plate, Access R H	1	
31	2-4130-007	Bracket, Aileron Hinge	4	
	50201	Bolt: AN3-14A	8	
	55392	Nut: AN365-1032C	8	
	58850	Washer: AN970-3	8	
32	2-4120-032	Trailing Edge, Wing	4	
33	2-4300-039	Strip, Nailing	8	
34	2-4300-038	Strip, Nailing	28	
35	2-4300-029	Plate, Reinforcement	4	
36	2-4300-030	Capstrip	4	
37	2-4100-032	Block, Trailing Edge	2	
38	2-4300-055	Block, Filler	2	
	2-4300-056	Block, Filler	2	
39	2-4300-052	Strip, Cove (inboard)	2	
	2-4300-053	Strip, Cove (outboard)	2	
40	2-4331-020	Rib, Lower Wing (station 53.00 & 79.00)	4	
41	2-4331-017	Rib, Lower Wing (station 26.50)	2	
42	2-4300-054	Block, Filler	2	
43	2-4300-057	Block, Filler (inboard)	2	
44	2-4300-058	Block, Filler (out board)	2	



FIGURE 3
UPPER WING ASSEMBLY



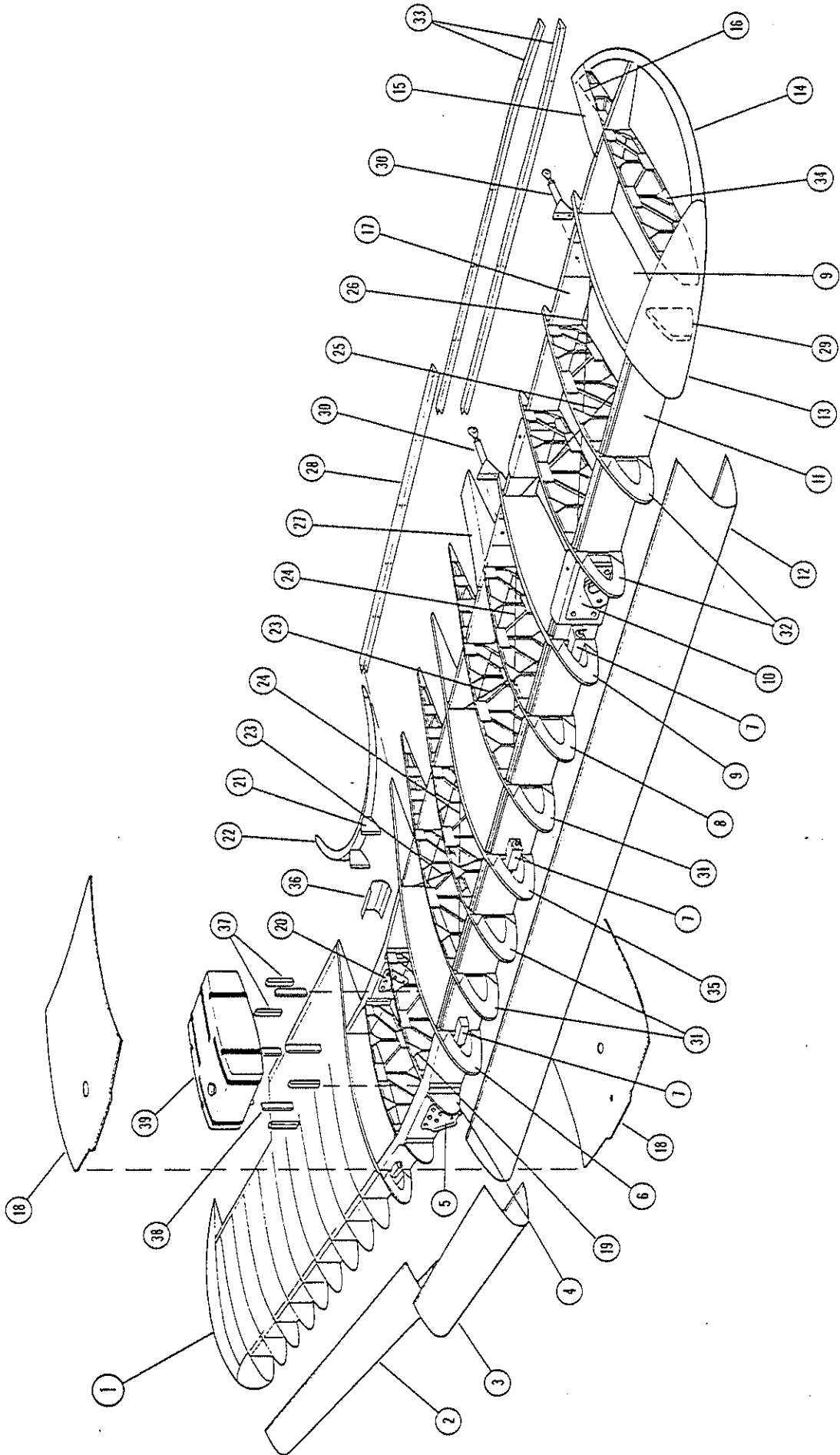

FIGURE 3: UPPER WING ASSEMBLY

FIGURE 3: UPPER WING ASSEMBLY

ITEM	PART NUMBER	DESCRIPTION	QTY	SERIAL NO'S AFFECTED
1	2-4100-001	Upper Wing Assembly	1	
2	77014	Leading Edge (right side)	1	
3	77016	Leading Edge (center)	1	
4	2-4121-000	Rib, Centersection	2	
	2-4100-018	Block, Corner	12	
5	2-4123-001	Fitting, Upper Wing	2	
	50453	Bolt: AN3-27A	2	
	55392	Nut: AN365-1032C	2	
	58740	Washer: AN960-10 (as required)	-	
	51326	Bolt: AN4-27A	3	
	55400	Nut: AN365-428A	3	
	58760	AN960-416 (as required)	-	
6	2-4109-017	Rib, Upper Wing L H (station 16.0)	1	
	2-4109-018	Rib, Upper Wing R H (station 16.0)	1	
7	2-4122-000	Block, Wire Pull	16	
8	2-4113-001	Rib, Upper Wing L H (station 63.5, left hand)	1	
	2-4113-002	Rib, Upper Wing R H (station 63.5, right hand)	1	
9	2-4109-025	Rib, Upper Wing (station 73.0 & 103.0, both sides)	4	
10	2-4321-000	Plate, Spar Reinforcement	4	
	2-4323-001	Bushing	2	
	2-4323-002	Bushing	4	
	2-4322-000	Lug, Flying Wire	4	
	53051	Bolt: AN8-42A	2	
	55526	Nut: AN365-820A	2	
	58805	Washer: AN960-816	6	
11	2-4101-000	Spar Assembly, Upper Front	1	
12	77014	Skin, Leading Edge (left side)	1	
13	2-4100-037	Wing Tip, Fiberglass	2	
14	2-4118-000	Bow, Wing Tip	2	
15	2-4100-016	Plate	4	
16	2-4300-030	Capstrip	4	
	2-4100-044	Doubler	2	
	2-4100-045	Strip, Nailing	2	
17	2-4103-000	Spar Assembly Upper Rear	1	
18	2-4100-014	Skin, Centersection	2	
19	2-4107-000	Rib, Upper Wing (station 8.0)	2	
20	2-4124-000	Fitting, Upper Wing (upper rear center)	2	
	50476	Bolt: AN3-30A	2	
	55392	Nut: AN365-1032C	2	
	58740	Washer: AN960-10 (as required)	-	
	51401	Bolt: AN4-31A	3	
	55400	Nut: AN365-428A	3	
	58760	Washer: AN960-416 (as required)	-	
21	2-4100-019	Rib, Hand Hold	2	
22	2-4106-000	Bow, Centersection	1	
23	76101	Drag Wire (38-1/4 inches long)	4	
24	76102	Drag Wire (42-1/2 inches long)	4	
25	76103	Drag Wire (39 inches long)	2	
26	76104	Drag Wire (44 inches long)	2	
	54548	Jam Nut: AN315-3 (for all drag wires)	48	
	58850	Washer: AN970-3 (for all drag wires)	24	
27	2-4100-015	Plate	4	
28	2-4120-001	Trailing Edge, Wing (inboard)	2	
29	2-4100-033	Rib, Nose	2	
30	2-4130-007	Bracket, Aileron Hinge	4	
	50176	Bolt: AN3-13A	8	

FIGURE 3: UPPER WING ASSEMBLY

ITEM	PART NUMBER	DESCRIPTION	QTY	SERIAL NO'S AFFECTED
	55392	Nut: AN365-1032C	8	
	58850	Washer: AN970-3	8	
31	2-4111-001	Rib, Upper Wing L H (stations 25.5, 35.0, 54.0)	3	
	2-4111-002	Rib, Upper Wing R H (stations 25.5, 35.0, 54.0)	3	
32	2-4115-001	Rib, Upper Wing L H (stations 83.0 & 93.0)	2	
	2-4115-002	Rib, Upper Wing R H (stations 83.0 & 93.0)	2	
33	2-4120-002	Trailing Edge, Wing (outboard)	4	
34	2-4117-021	Rib, Upper Tip L H (station 111.5)	1	
	2-4117-022	Rib, Upper Tip R H (station 111.5)	1	
35	2-4109-019	Rib, Upper Wing L H (station 44.5)	1	
	2-4109-020	Rib, Upper Wing R H (station 44.5)	1	
36	2-4100-030	Plate, Cover	1	
37	2-4100-041	Spacer, Aux Tank (front & rear)	4	
38	2-4100-042	Spacer, Aux Tank (sides)	4	
39	2-1020-003	Fuel Tank Assembly (see Figure 17)	1	

FIGURE 4
AILERON ASSEMBLY

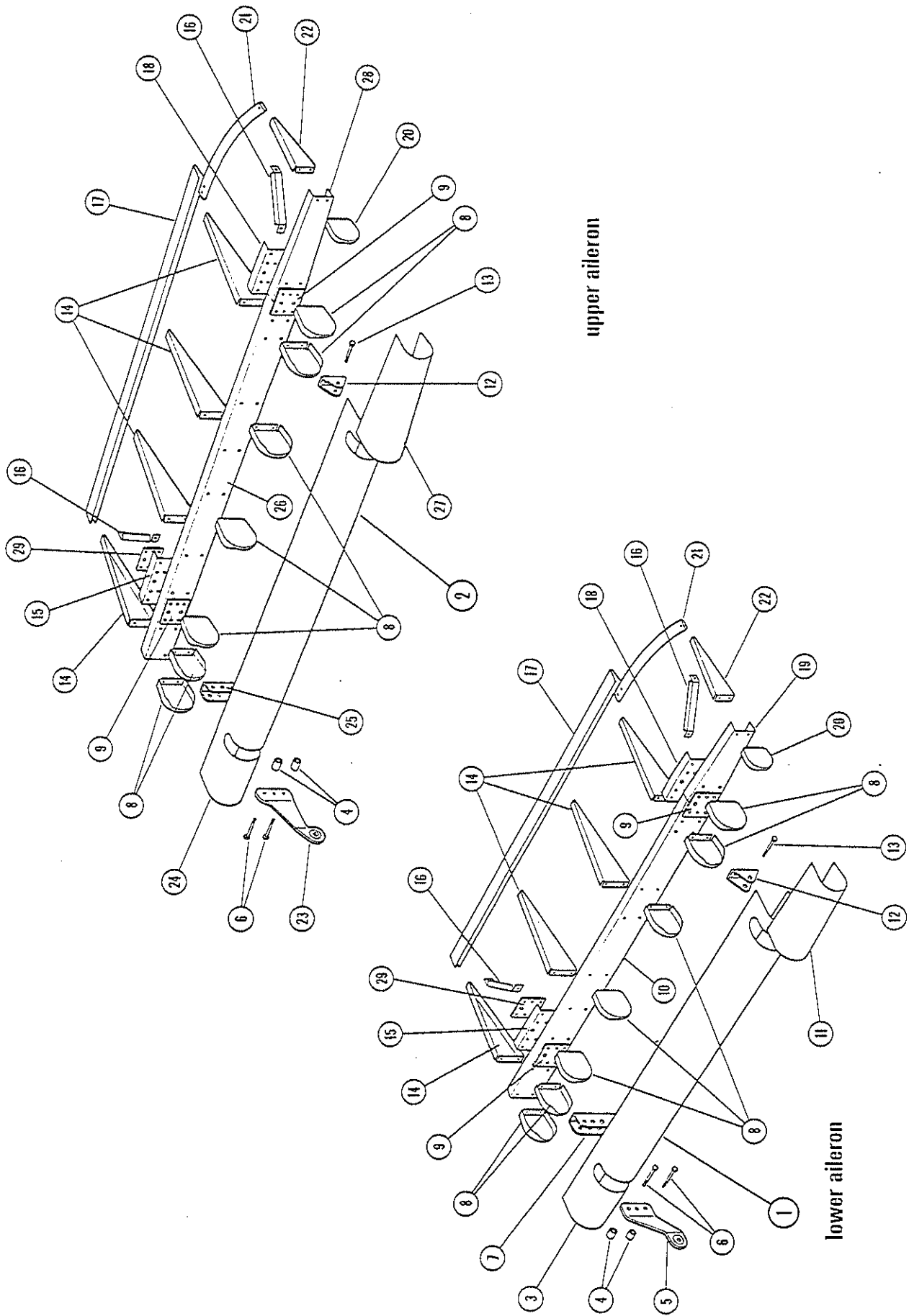

upper aileron

lower aileron

FIGURE 4: AILERON ASSEMBLY

FIGURE 4: AILERON ASSEMBLY

ITEM	PART NUMBER	DESCRIPTION	QTY	SERIAL NO.'S AFFECTED
1	2-4400-051	Aileron, Lower L H	1	
	2-4400-052	Aileron, Lower R H	1	
2	2-4200-051	Aileron, Upper L H	1	
	2-4200-052	Aileron, Upper R H	1	
3	2-4400-061	Skin, Aileron Leading Edge L H	1	
	2-4400-062	Skin, Aileron Leading Edge R H	1	
4	1-0440-039	Spacer	8	
5	2-4400-080	Arm, Aileron Control	2	
6	50151	Bolt: AN3-12A	8	
	55392	Nut: AN365-1032C	8	
	58740	Washer: AN960-10	12	
	2-4400-073	Hinge, Lower Aileron	2	
7	50026	Bolt: AN3-5A	4	
	55392	Nut: AN365-1032C	4	
	58740	Washer: AN960-10	4	
	2-4400-053	Rib, Aileron Leading Edge	28	
9	77109	Plate	8	
10	2-4400-063	Spar, Aileron	2	
11	2-4400-077	Skin, Aileron Tip	2	
12	2-4400-075	Hinge, Aileron	4	
	50026	Bolt: AN3-5A	8	
	55392	Nut: AN365-1032C	8	
	58740	Washer: AN960-10	8	
13	50126	Bolt: AN3-11A	4	
	55392	Nut: AN365-1032C	4	
	58740	Washer: AN960-10	4	
	2-4400-057	Rib, Main	16	
15	2-4400-065	Channel	4	
16	2-4400-006	Angle	8	
17	2-4400-007	Trailing Edge	4	
18	2-4400-067	Channel	4	
19	2-4400-079	Tip, Spar	2	
20	2-4400-055	Rib, Nose	4	
21	2-4400-009	Trailing Edge, Aileron	4	
22	2-4400-059	Rib, Aileron Tip	4	
23	2-4200-063	Arm, Aileron Control L H	1	
	2-4200-064	Arm, Aileron Control R H	1	
24	2-4200-053	Skin, Aileron Leading Edge	2	
25	2-4200-057	Hinge, Aileron	2	
26	2-4200-055	Spar, Aileron	2	
27	2-4200-059	Skin, Aileron Tip	2	
28	2-4200-061	Spar, Tip	2	
29	77108	Plate	4	



This page
intentionally blank.





FIGURE 5
FUSELAGE STRUCTURE



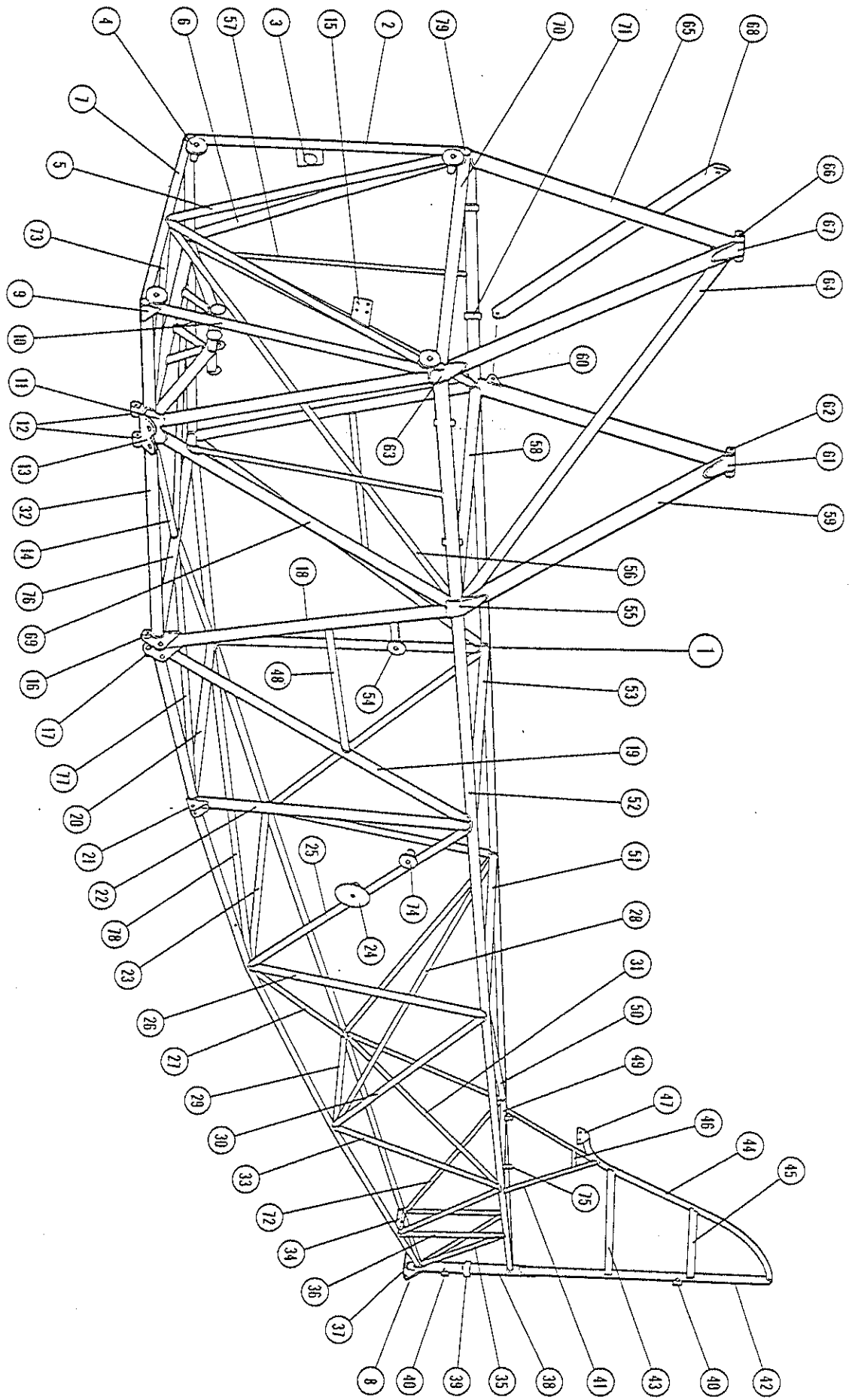

FIGURE 5: FUSELAGE STRUCTURE

FIGURE 5: FUSELAGE STRUCTURE

ITEM	PART NUMBER	DESCRIPTION	QTY	SERIAL NO'S ATTACHED
1	2-2100-005	Fuselage Frame Assembly	1	
2	2-2100-140	Tube, R H	1	
3	2-2100-268	Bracket, Fuel Valve	1	
4	79024	Bushing	4	
	58880	Washer: AN970-6	4	
5	2-2100-165	Tube, L H	1	
	2-2100-166	Tube, R H	1	
6	2-2100-242	Tube, Diagonal R H	1	
	2-2100-241	Tube, Diagonal L H	1	
7	2-2100-153	Tube	1	
8	2-2100-134	Gusset, Fuselage	1	
9	2-2100-131	Gusset, Side (shown)	2	
	2-2100-133	Gusset, Bottom (not shown)	2	
10	2-2100-139	Tube, L H	1	
11	76030	Support, Flying Wire	2	
12	79216	Lug, Landing Gear	4	
13	76074	Bracket, Flying Wire	2	
14	2-2100-199	Tube (both sides)	2	
15	2-2100-176	Bracket, Fuel Pump	1	
16	2-2115-001	Bracket (left side)	1	
	2-2115-002	Bracket (right side)	1	
17	2-2115-003	Bracket (left side)	1	
	2-2115-004	Bracket (right side)	1	
18	2-2100-245	Tube, Diagonal L H	1	
	2-2100-246	Tube, Diagonal R H	1	
19	2-2100-249	Tube, Diagonal L H	1	
	2-2100-250	Tube, Diagonal R H	1	
20	2-2100-219	Tube	1	
21	76090	Fitting	2	
22	2-2100-063	Tube, L H	1	
	2-2100-064	Tube, R H	1	
23	2-2100-071	Tube	1	
24	2-2124-001	Elevator Trim Bushing Assembly	1	
	2-2100-129	Plate, Trim Tab	1	
25	2-2100-065	Tube, L H	1	
	2-2100-066	Tube, R H	1	
26	2-2100-067	Tube, L H	1	
	2-2100-068	Tube, R H	1	
27	2-2100-062	Tube	1	
28	2-2100-111	Tube	1	
29	2-2100-098	Tube	1	
30	2-2100-069	Tube, L H	1	
	2-2100-070	Tube, R H	1	
31	2-2100-113	Tube	1	
32	2-2100-239	Tube, Longerons Bottom L H	1	
	2-2100-240	Tube, Longerons Bottom R H	1	
33	2-2100-073	Tube, L H	1	
	2-2100-074	Tube, R H	1	
34	2-2100-102	Tube	1	
35	2-2100-103	Tube, L H	1	
	2-2100-104	Tube, R H	1	
36	2-2100-105	Tube (both sides)	2	
37	76094	Bracket	1	
38	2-2100-101	Tube	1	
39	2-2100-110	Stop, Rudder	1	
40	76083	Pad	2	

FIGURE 5: FUSELAGE STRUCTURE

ITEM	PART NUMBER	DESCRIPTION	QTY	SERIAL NO.'S AFFECTED
41	2-2100-077	Tube, L H	1	
	2-2100-078	Tube, R H	1	
42	2-2100-082	Tube	1	
43	2-2100-079	Channel	1	
44	2-2100-081	Tube, Fin Leading Edge	1	
45	2-2100-080	Channel	1	
46	2-2100-099	Tube	1	
47	76015	Plate	1	
48	2-2100-265	Tube, Support	2	
49	2-2100-096	Tube	1	
50	2-2100-112	Tube	1	
51	2-2100-072	Tube	1	
52	2-2100-021	Tube, Longeron Top L H	1	
	2-2100-022	Tube, Longeron Top R H	1	
53	2-2100-046	Tube	1	
54	2-2100-281	Tube, Throttle Support	1	
	79223	Bushing	1	
	58870	Washer: AN970-5	1	
55	76029	Strap, Cabane (lower aft)	2	
56	2-2100-263	Tube, Diagonal L H	1	
	2-2100-264	Tube, Diagonal R H	1	
57	2-2100-015	Tube, L H	1	
	2-2100-016	Tube, R H	1	
58	2-2100-256	Tube	1	
59	2-2100-277	Strut, Cabane L H	1	
	2-2100-278	Strut, Cabane R H	1	
60	76053	Lug, Cabane Strut	2	
61	76025	Strap, Cabane (upper aft)	1	
62	79221	Bushing	1	
63	76028	Strap, Cabane (lower forward)	2	
64	2-2100-253	Brace, Cabane	1	
65	2-2100-251	Strut, Cabane L H	1	
	2-2100-252	Strut, Cabane R H	1	
66	79220	Bushing	1	
67	76026	Strap, Cabane (upper forward)	1	
68	2-2000-002	Brace, Cabane	1	
69	2-2100-243	Tube, Diagonal L H	1	
	2-2100-244	Tube, Diagonal R H	1	
70	2-2100-151	Tube	1	
71	79146	Bushing	4	
72	2-2100-075	Tube, L H	1	
	2-2100-076	Tube, R H	1	
73	2-2100-247	Tube, Diagonal Bottom	1	
	2-2100-248	Tube, Diagonal Bottom	1	
74	79223	Bushing	1	
	58870	Washer: AN970-5	1	
75	79217	Bushing	2	
76	2-2100-221	Tube	1	
77	2-2100-215	Tube (both sides)	1	
78	2-2100-255	Tube	1	
79	76010	Cap	4	

FIGURE 6
FUSELAGE TABS & BRACKETS

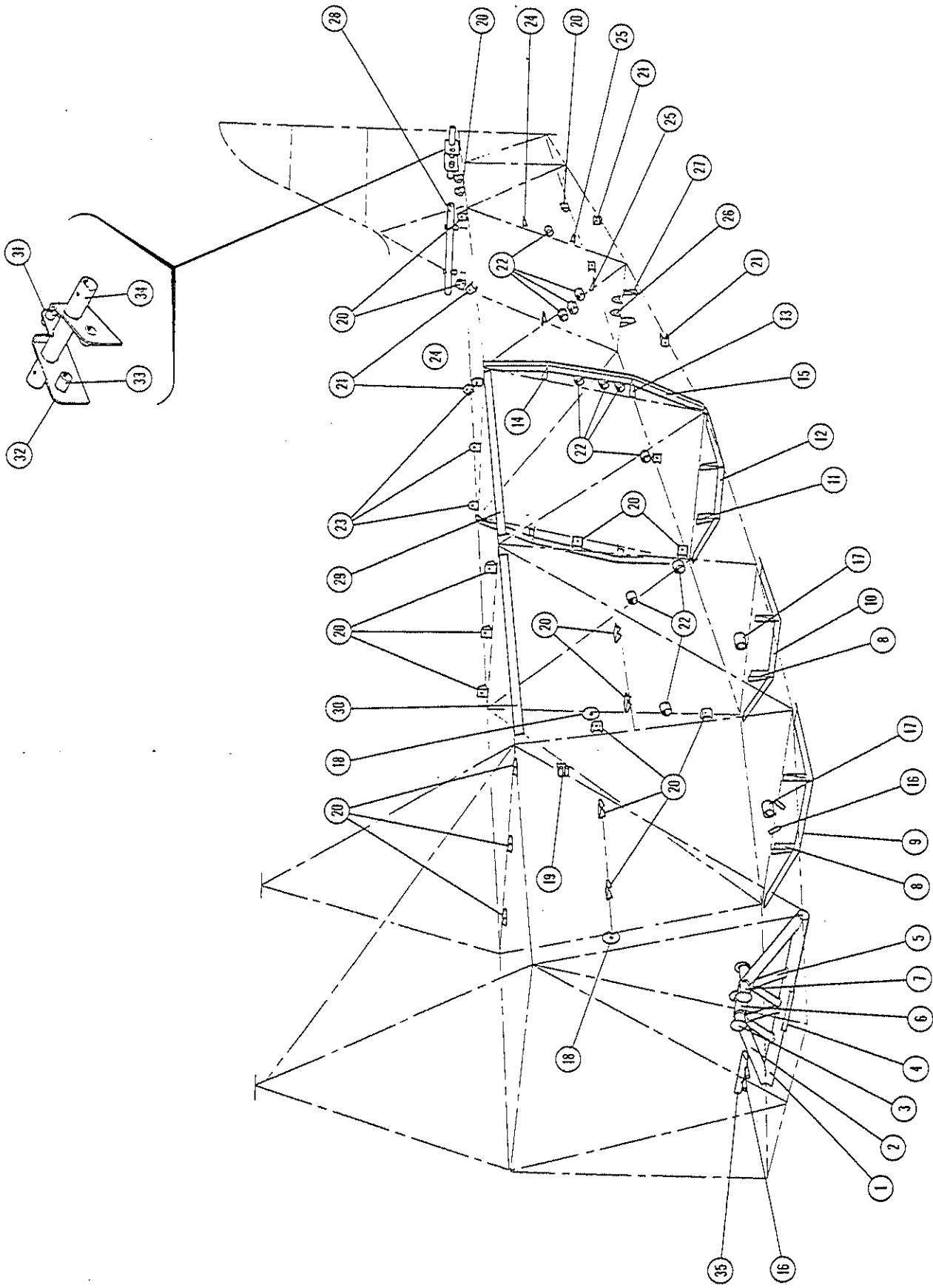

FIGURE 6: FUSELAGE TABS & BRACKETS

() () ()

FIGURE 6: FUSELAGE TABS & BRACKETS

ITEM	PART NUMBER	DESCRIPTION	QTY	SERIAL NO.'S AFFECTED
1	2-2100-193	Tube	1	
2	2-2100-035	Tube (both sides)	2	
3	58860	Washer: AN970-4	4	
4	2-2114-001	Channel, Bumper	1	
5	2-2100-197	Tube, Bungee Truss	4	
6	2-2100-201	Tube, Bungee Truss	1	
7	2-2100-033	Tube (both sides)	2	
8	76041	Angle, Fairing (left side)	2	
	76042	Angle, Fairing (right side)	2	
9	2-2100-274	Angle, Belly Fairing	1	
10	2-2100-271	Angle, Belly Fairing	1	
11	76039	Angle, Fairing (left side)	1	
	76040	Angle, Fairing (right side)	1	
12	2-2100-272	Angle, Belly Fairing	1	
13	76034	Angle, Fairing	2	
14	76033	Angle, Fairing	2	
15	2-2100-269	Angle, Fairing L H	1	
	2-2100-270	Angle, Fairing R H	1	
16	79217	Bushing	4	
17	2-5120-001	Bushing Assembly	2	
18	58880	Washer, Large Area: AN970-6	2	
19	76019	Clamp, Throttle	1	
20	76092	Tab	21	
21	76075	Tab	6	
22	79016	Bushing, Fairlead	11	
23	76016	Bracket	3	
24	76031	Angle, Fairing	4	
25	76032	Angle, Fairing	4	
26	76099	Bracket, Control Arm Idler	2	
27	76038	Angle, Fairing (left side)	1	
	76037	Angle, Fairing (right side)	1	
28	2-2123-001	Stabilizer Support Assembly	1	
29	2-2112-005	Angle, Cowl Attach (both sides)	2	
30	2-2112-006	Angle, Cowl Attach (both sides)	2	
31	76098	Bracket, Bearing Support	1	
	79217	Bushing	1	
32	76051	Bracket (left side)	1	
	76052	Bracket (right side)	1	
33	79218	Bushing	2	
34	2-2100-109	Tube	1	
35	2-2100-280	Tube, Strainer Support	1	



This page
intentionally blank.





FIGURE 7
FUSELAGE FAIRINGS



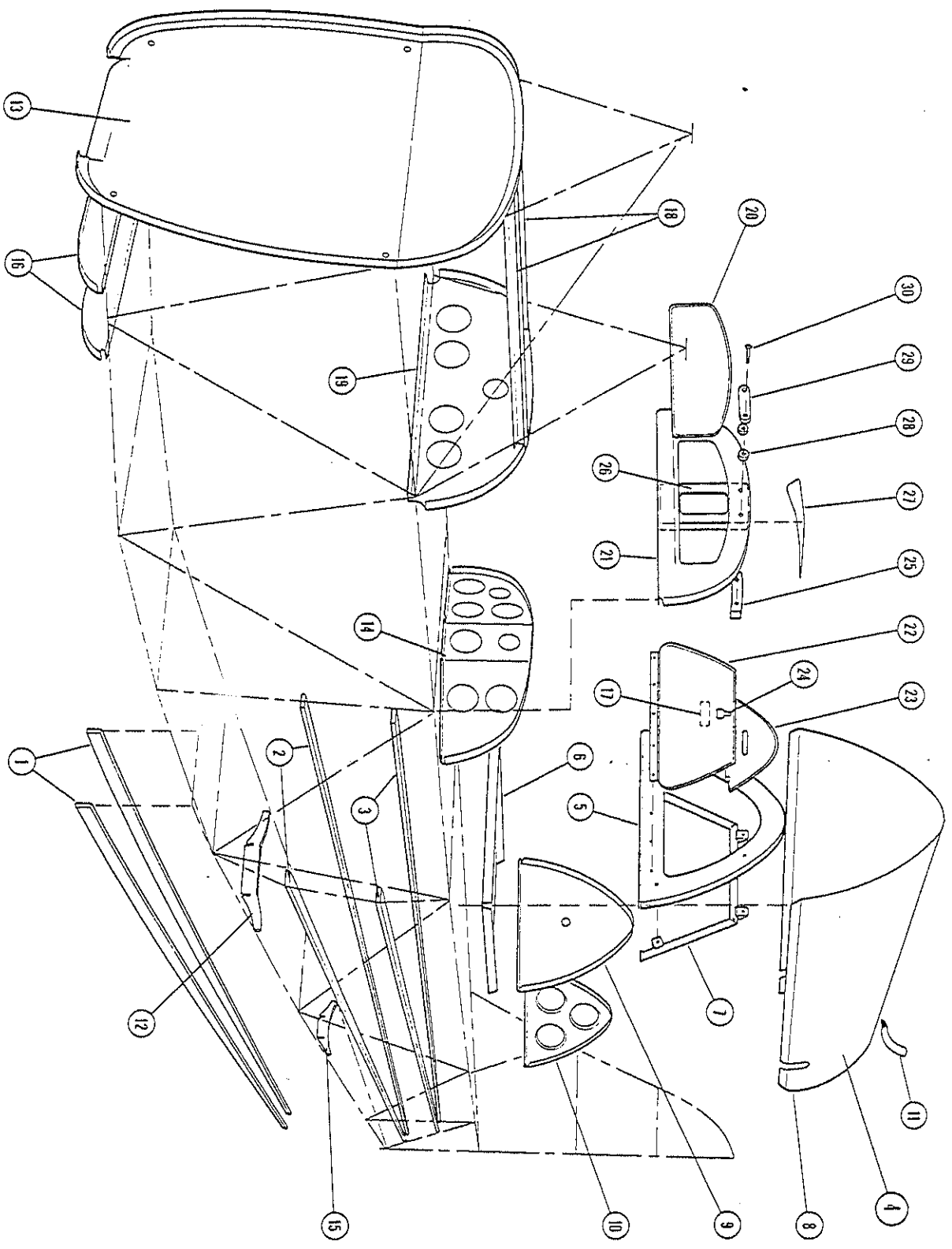

FIGURE 7: FUSELAGE FAIRINGS

FIGURE 7: FUSELAGE FAIRINGS

ITEM	PART NUMBER	DESCRIPTION	QTY	SERIAL NO.'S AFFECTED
1	2-2221-007	Stringer, Bottom	2	
2	2-2221-008	Stringer, Lower Side	2	
3	2-2221-009	Stringer, Upper Side	2	
4	2-2200-001	Turtledeck Assembly	1	
5	2-2200-012	Bulkhead, Front	1	
6	2-2200-515	Floor, Baggage Compartment	1	
7	2-2200-020	Harness Support Assembly	1	
	56850	Screw: AN526-1032R8	4	
	55601	Nut: AN365-1032A	4	
8	2-2200-011	Skin, Turtledeck	1	
9	2-2200-014	Bulkhead, Center	1	
10	2-2200-013	Bulkhead, Rear	1	
11	2-4143-011	Fairing	1	
12	2-2220-001	Former, Forward Fuselage	1	
13	2-2262-007	Firewall Assembly	1	
14	2-2224-003	Panel, Rear Instrument	1	
15	2-2222-001	Former, Aft Fuselage	1	
16	2-2251-003	Bulkhead, Lower	2	
17	75022	Placard, Max Baggage Limits	1	
18	2-2248-003	Channel Assembly, L H	1	
	2-2248-004	Channel Assembly, R H	1	
19	2-2204-005	Panel, Forward Instrument	1	
20	2-2249-003	Plate, Cover	1	
21	2-2249-002	Bulkhead, Top	1	
22	2-2201-001	Baggage Door Assembly	1	
23	2-2201-014	Cover Plate	1	
24	62150	Latch, Panel	1	
25	76226	Corner Block	1	
26	2-2249-005	Channel	1	
27	2-2249-004	Stiffener	1	
28	76227	Washer	2	
29	76228	Support Bar	1	
30	56582	Screw: AN507-428R22	2	
	55400	Nut: AN365-428A	2	

This page
intentionally blank.

FIGURE 8
COVERED FUSELAGE

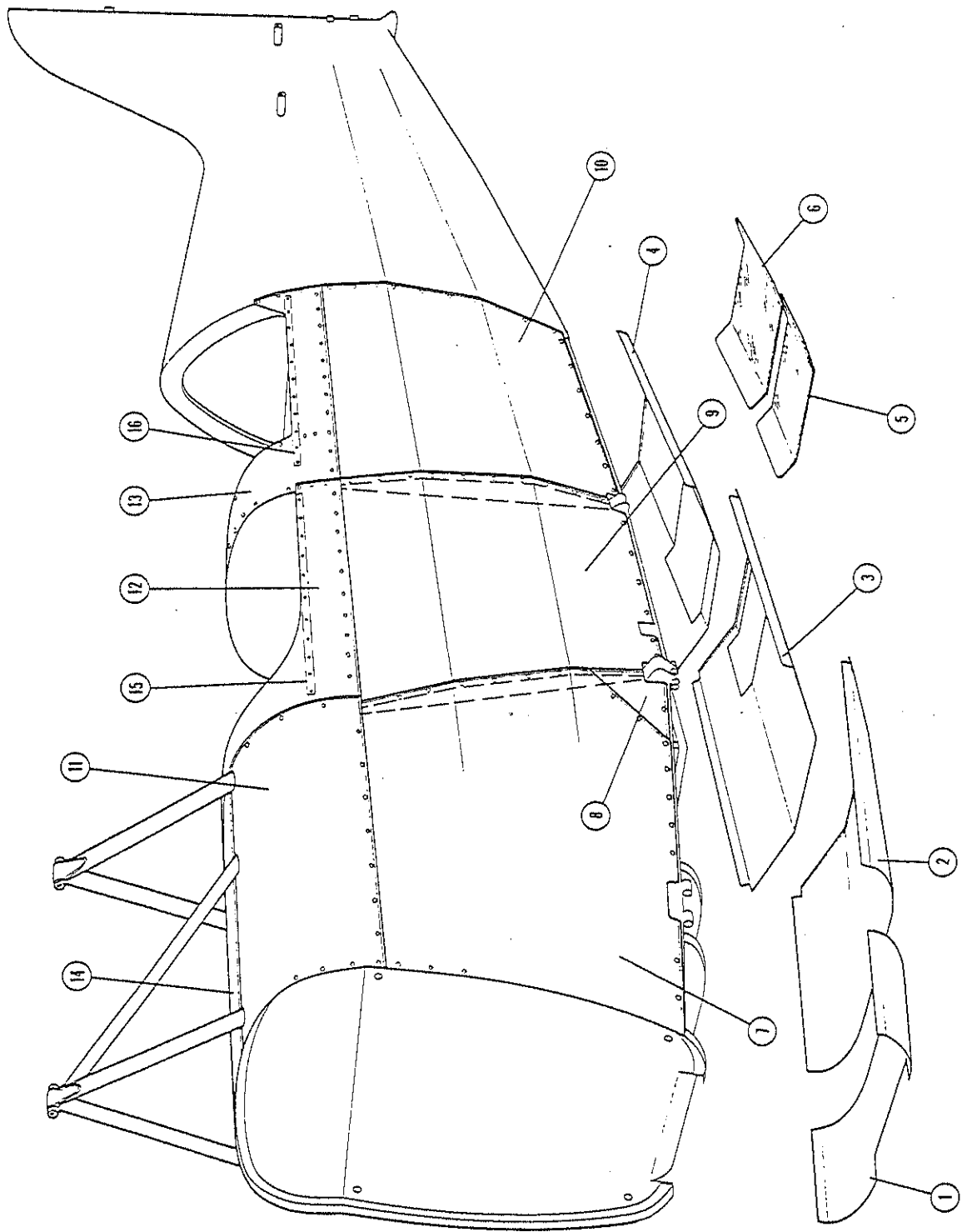

FIGURE 8: COVERED FUSELAGE

() () ()

FIGURE 8: COVERED FUSELAGE

ITEM	PART NUMBER	DESCRIPTION	QTY	SERIAL NO.'S AFFECTED
1	2-2273-020	Panel, Bottom Forward	1	
2	2-2273-019	Panel, Bottom Aft	1	
3	2-2273-012	Panel, Cockpit Belly	1	
4	2-2273-005	Panel, Aft Belly	1	
5	2-2273-013	Window, Forward Belly	1	
6	2-2273-006	Window, Aft Belly	1	
7	2-2273-017	Panel, Side L H	1	
	2-2273-018	Panel, Side R H	1	
8	2-2273-027	Gusset, Side Panel L H	1	
	2-2273-028	Gusset, Side Panel R H	1	
9	2-2273-009	Panel, Side Forward L H	1	
	2-2273-010	Panel, Side Forward R H	1	
10	2-2273-003	Panel, Side Aft L H	1	
	2-2273-004	Panel, Side Aft R H	1	
11	2-2273-015	Panel, Top L H	1	
	2-2273-016	Panel, Top R H	1	
12	2-2273-007	Panel, Forward Cockpit	1	
13	2-2273-001	Panel, Aft Cockpit	1	
14	2-2273-014	Panel, Top Center	1	
15	2-2273-008	Channel, Forward Cockpit (both sides)	2	
16	2-2273-025	Channel, Aft Cockpit L H	1	
	2-2273-026	Channel, Aft Cockpit R H	1	

This page
intentionally blank.



FIGURE 9

SEAT & FLOORBOARD INSTALLATION



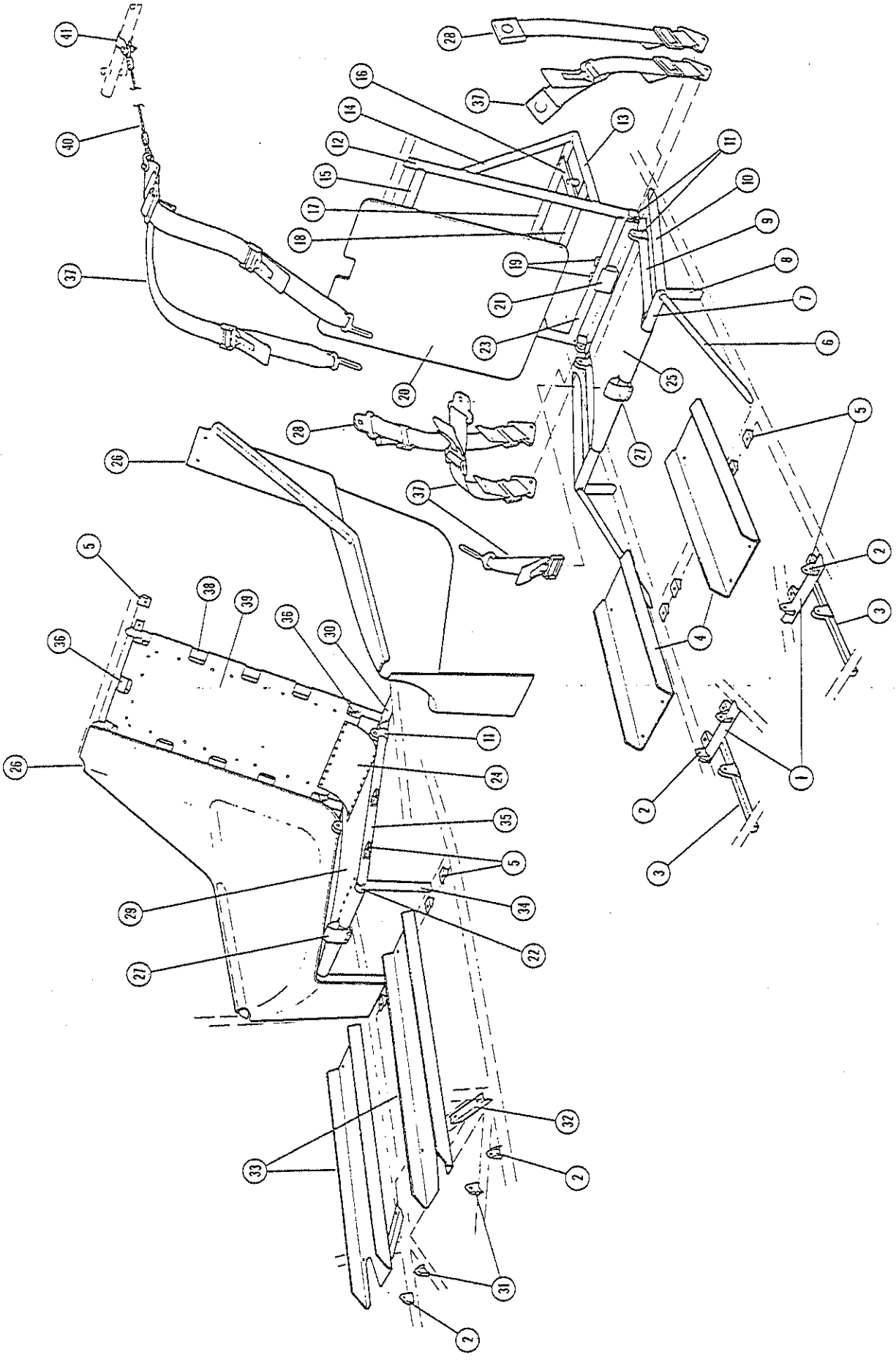

FIGURE 9: SEAT & FLOORBOARD INST.

FIGURE 9: SEAT & FLOORBOARD INSTALLATION

ITEM	PART NUMBER	DESCRIPTION	QTY	SERIAL NO.'S AFFECTED
1	2-2100-266	Tube, Pedal Support	2	
2	76022	Bracket, Rudder Pedal	6	
3	2-2100-267	Tube, Pedal Support	2	
	76022	Bracket, Rudder Pedal	4	
4	2-2238-003	Channel, Rear Floor L H	1	
	2-2238-004	Channel, Rear Floor R H	1	
5	76091	Tab	18	
6	2-2100-275	Tube, Seat L H	1	
	2-2100-276	Tube, Seat R H	1	
7	2-2100-114	Tube	1	
8	2-2100-115	Tube, L H	1	
	2-2100-116	Tube, R H	1	
9	2-2100-093	Tube, L H	1	
	2-2100-094	Tube, R H	1	
10	2-2100-119	Tube, L H	1	
	2-2100-120	Tube, R H	1	
11	76095	Clamp	6	
12	2-2100-100	Tube	2	
13	2-2125-005	Tube (left side)	1	
	2-2125-004	Tube (right side)	1	
14	2-2125-011	Tube	2	
15	2-2100-123	Tube	1	
16	2-2125-002	Angle	2	
17	2-2125-010	Tube	1	
18	2-2125-003	Tube	1	
19	76099	Bracket, Control Arm Idler	2	
20	2-2243-001	Back assembly, Rear Seat	1	
21	76014	Support, Channel	1	
22	2-2100-089	Tube	1	
23	2-2100-095	Tube	1	
24	2-2240-003	Panel, Front Seat	1	
25	2-2241-001	Seat, Bottom Rear	1	
26	2-2240-001	Armrest, Seat L H	1	
	2-2240-002	Armrest, Seat R H	1	
27	822-M	Connector, Crotch Strap	2	
28	821	Secondary Seat Belt	2	
29	2-2240-004	Seat, Bottom Front	1	
30	2-2100-090	Tube	1	
31	76021	Bracket, Rudder Pedal	2	
32	2-2100-213	Support, Floorboard L H	1	
	2-2100-214	Support, Floorboard R H	1	
33	2-2239-003	Channel, Front Floor L H	1	
	2-2239-004	Channel, Front Floor R H	1	
34	2-2100-085	Tube, L H	1	
	2-2100-086	Tube, R H	1	
35	2-2100-087	Tube, L H	1	
	2-2100-088	Tube, R H	1	
36	2-2100-092	Tube	2	
37	820	Seat Belt/Harness System	2	
	820-SET	Seat Belt/Harness System with 823A Lap Pad Set	2	
38	2-2100-091	Tube	2	
39	2-2244-001	Back, Front Seat	1	
40	2-2280-011	Cable Assembly	1	
41	2-2122-001	Clamp	1	

REV 8-22-88

This page
intentionally blank.



FIGURE 10
TAIL SURFACES INSTALLATION



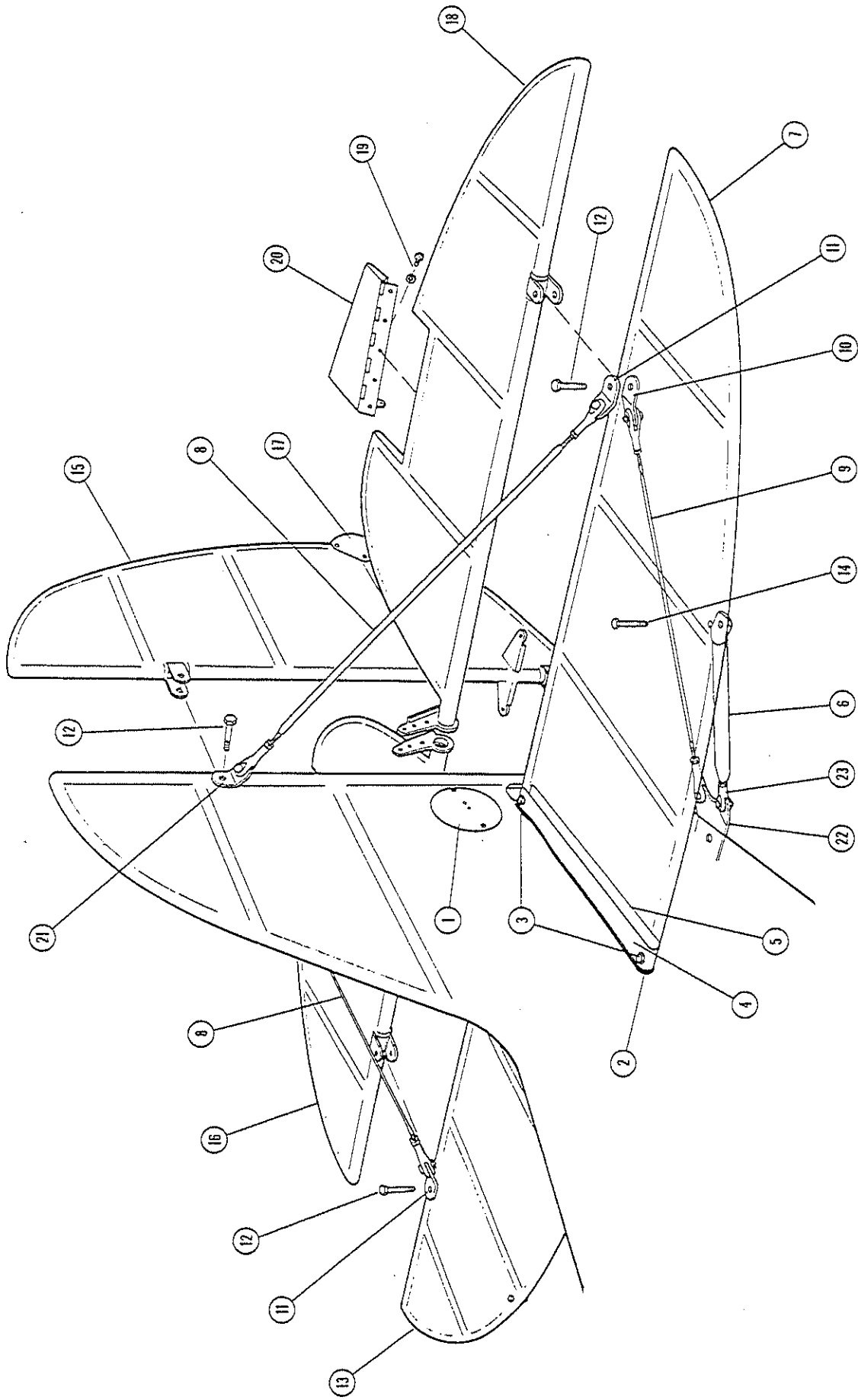

FIGURE 10: TAIL SURFACES INSTALLATION

FIGURE 10: TAIL SURFACES INSTALLATION

ITEM	PART NUMBER	DESCRIPTION	QTY	SERIAL NO.'S AFFECTED
1	61659	Cover, Inspection Hole	2	
2	40149	Channel, Rubber (D-Type)	8.5 ft	
3	50151	Bolt: AN3-12A	4	
	58740	Washer: AN960-10	4	
	55392	Nut: AN365-1032C	4	
4	2-1003-029	Fairing, Stabilizer Upper L H	1	
	2-1003-030	Fairing, Stabilizer Upper R H	1	
5	2-1003-031	Fairing, Stabilizer Lower L H	1	
	2-1003-032	Fairing, Stabilizer Lower R H	1	
6	2-3100-025	Brace, Stabilizer L H	1	
	2-3100-024	Brace, Stabilizer R H	1	
7	2-3100-501	Stabilizer Assembly L H (covered and painted)	1	
8	57060	Tie Rod, Type 11: AN674-C (35 inches long)	2	
	56954	Terminal, Tie Rod: AN665-34L	2	
	56955	Terminal, Tie Rod: AN665-34R	2	
	54550	Nut: AN315-4R	2	
	56015	Pin, Clevis: AN394-15	2	
	55675	Pin, Cotter: AN380-2-2	2	
9	57050	Tie Rod, Type 11: AN674-C (31 inches long)	2	
	56954	Terminal, Tie Rod: AN665-34L	2	
	56955	Terminal, Tie Rod: AN665-34R	2	
	54550	Nut: AN315-4R	2	
	56015	Pin, Clevis: AN394-15	2	
	55675	Pin, Cotter: AN380-2-2	2	
10	2-1000-005	Lug, Tail Wire	2	
11	2-1000-003	Lug, Tail Wire	2	
12	51125	Bolt: AN4-17	3	
	58760	Washer: AN960-416	6	
	54400	Castle Nut: AN310-4	3	
	55675	Cotter Pin: AN380-2-2	3	
13	2-3100-502	Stabilizer Assembly R H (covered and painted)	1	
14	50176	Bolt: AN3-13A	2	
	55392	Nut: AN365-1032C	2	
	58740	Washer: AN960-10	2	
15	2-3300-501	Rudder Assembly (covered and painted)	1	
16	2-3200-502	Elevator Assembly R H (covered and painted)	1	
17	2-3300-018	Tab, Rudder Trim	1	
18	2-3200-501	Elevator Assembly L H (covered and painted)	1	
19	50001	Bolt: AN3-3A	5	
	58740	Washer: AN960-10	5	
20	2-3220-001	Tab, Elevator L H	1	
	2-3220-002	Tab, Elevator R H	1	
21	2-1000-007	Lug, Tail Wire	2	
22	2-2117-001	Fitting, Butterfly	1	
	52450	Bolt: AN6-22	1	
	54450	Nut: AN310-6	1	
	58790	Washer: AN960-616	2	
	55750	Cotter Pin: AN380-3-3	1	
23	54090	Fork: AN161-32RS	2	
	50076	Bolt: AN4-7A	2	
	58770	Washer: AN960-416L	2	
	58760	Washer: AN960-416	4	
	55400	Nut: AN365-428	2	

This page
intentionally blank.



FIGURE 11
TAIL SURFACES ASSEMBLY



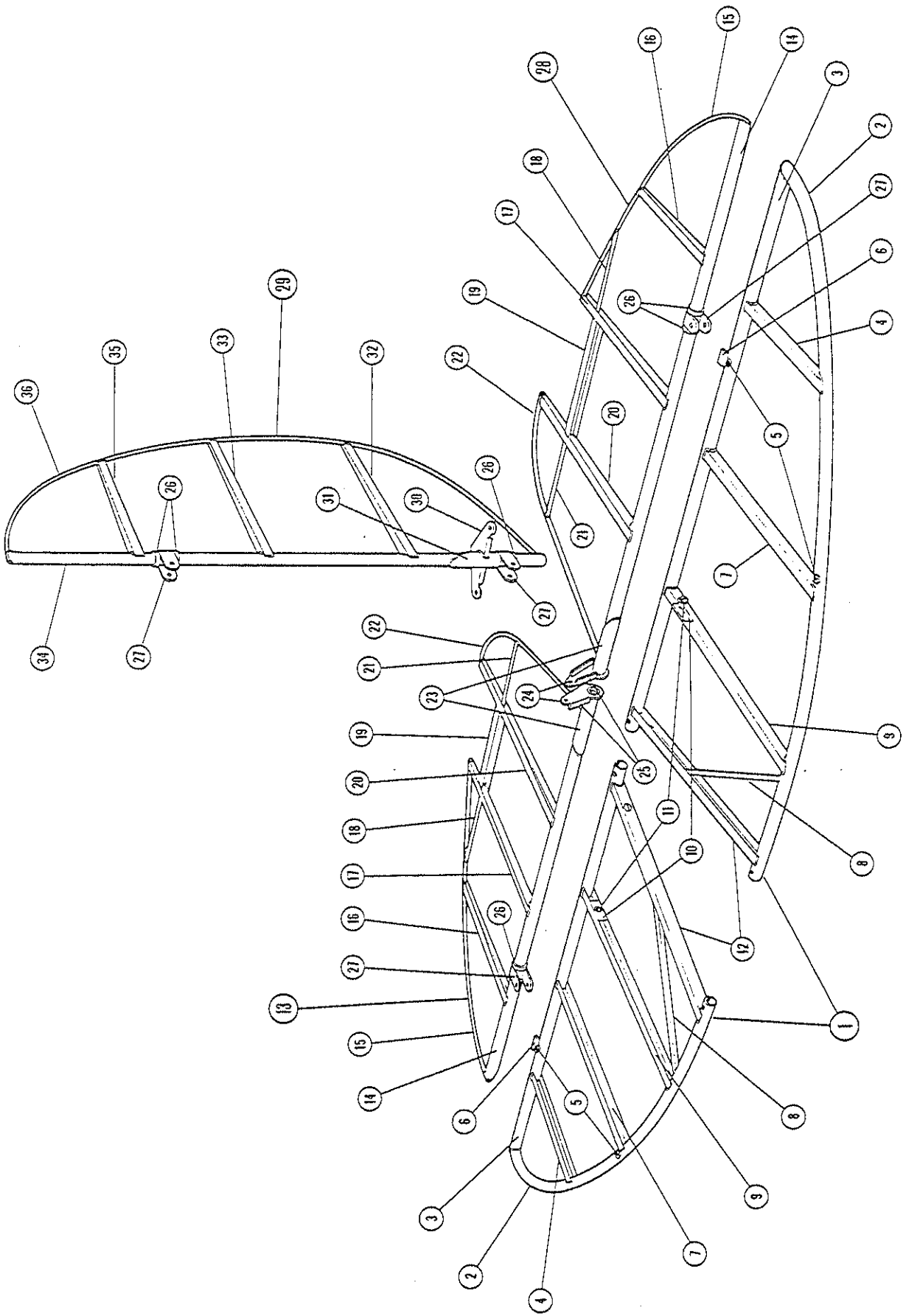

FIGURE 11: TAIL SURFACES ASSEMBLY

FIGURE 11: TAIL SURFACES ASSEMBLY

ITEM	PART NUMBER	DESCRIPTION	QTY	SERIAL NO.'s AFFECTED
1	2-3100-001	Weldment, Stabilizer	2	
2	2-3100-012	Leading Edge, Stabilizer	2	
3	2-3100-011	Spar, Stabilizer	2	
4	2-3100-016	Rib, Stabilizer	2	
5	79010	Bushing	2	
6	76083	Hinge Pad	2	
7	2-3100-015	Rib, Stabilizer	2	
8	2-3100-017	Brace, Stabilizer	2	
9	2-3100-014	Rib, Stabilizer	2	
10	2-3100-018	Plate, Stabilizer	2	
11	79265	Bushing	2	
12	2-3100-013	Rib, Stabilizer	2	
13	2-3200-002	Weldment, Elevator R H	1	
14	2-3200-011	Spar, Elevator	2	
15	2-3200-012	Tube, Trailing Edge	2	
16	2-3200-019	Rib, Elevator	2	
17	2-3200-018	Rib, Elevator	2	
18	2-3200-022	Tube	2	
19	2-3200-014	Support, Trim Tab	2	
20	2-3200-017	Rib, Elevator	2	
21	2-3200-023	Tube	2	
22	2-3200-012	Tube, Trailing Edge	2	
23	2-3200-020	Reinforcement, Sleeve	2	
24	76084	Elevator Horn L H	1	
	76085	Elevator Horn R H	1	
25	2-3200-024	Flange, Elevator Horn	2	
26	79280	Retainer	7	
27	2-3210-001	Hinge Assembly	4	
28	2-3200-001	Weldment, Elevator L H	1	
29	2-3300-001	Weldment, Rudder	1	
30	76089	Rudder Horn	1	
31	2-3200-020	Reinforcement, Sleeve	1	
32	2-3300-013	Rib, Rudder	1	
33	2-3300-012	Rib, Rudder	1	
34	2-3300-015	Spar, Rudder	1	
35	2-3300-014	Rib, Rudder	1	
36	2-3300-016	Tube, Trailing Edge	1	

This page
intentionally blank.



FIGURE 12
LANDING GEAR INSTALLATION



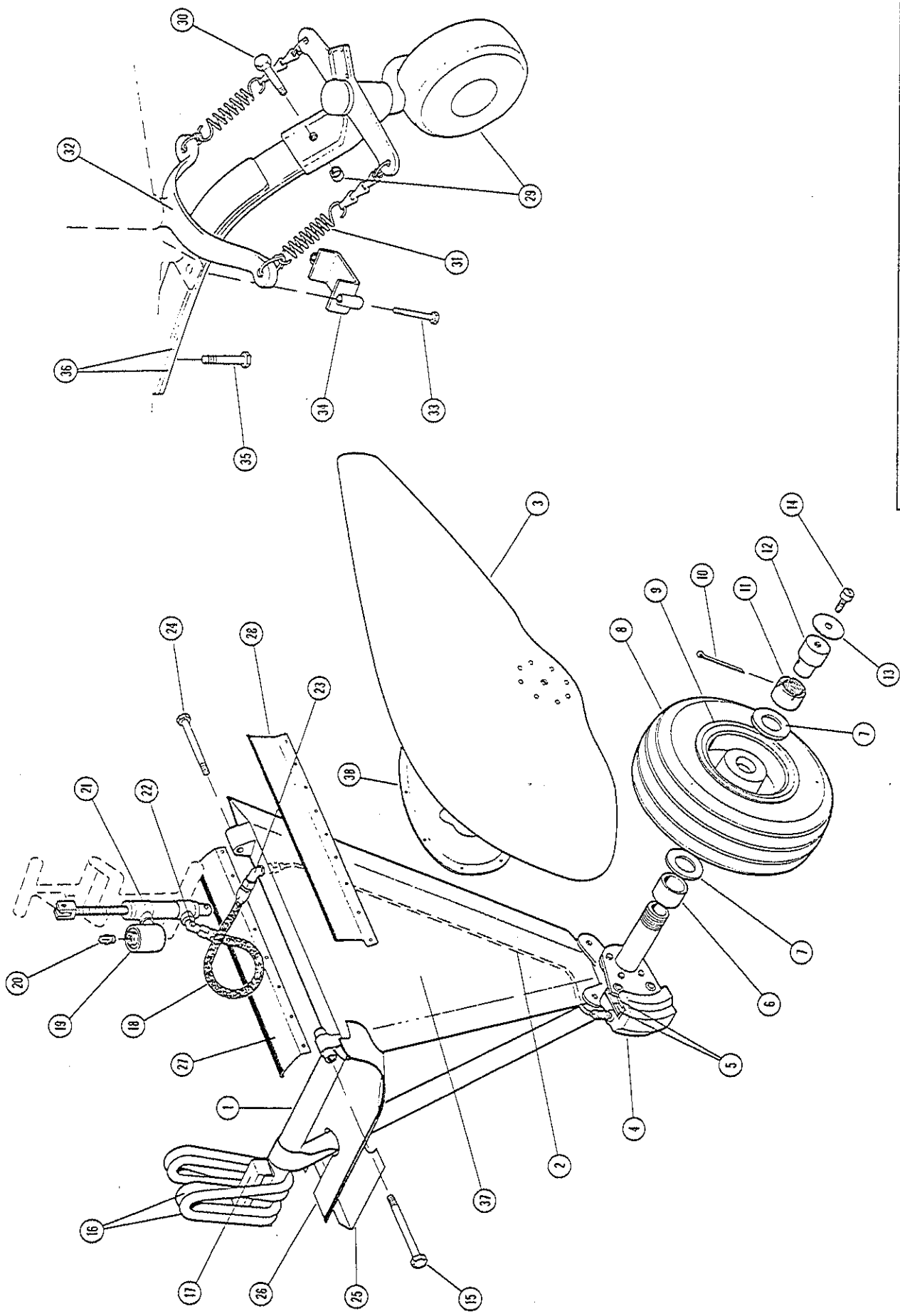

FIGURE 12: LANDING GEAR INSTALLATION

FIGURE 12: LANDING GEAR INSTALLATION

ITEM	PART NUMBER	DESCRIPTION	QTY	SERIAL NO.'S AFFECTED
1	2-2300-051	Strut Assembly, Landing Gear L H	1	
	2-2300-052	Strut Assembly, Landing Gear R H	1	
2	2-2302-002	Brake Line Assembly	2	
3	2-1003-071	Fairing, Wheel L H	1	
	2-1003-072	Fairing, Wheel R H	1	
4	60401	Brake Assembly, Cleveland 30-9	2	
5	60405	Lining, Cleveland 66-2	4	
	60410	Rivet, Cleveland 066-00200	12	
6	78019	Wheel Spacer	2	
7	78020	Grease Seal Spacer	4	
8	63875	Tire, 5:00 x 5, 6 Ply	2	
	63902	Tube, 5:00 x 5	2	
9	63955	Wheel Assembly: Cleveland 40-78B	2	
10	55870	Cotter Pin: AN380-4-10	2	
11	78021	Nut, Axle	2	
12	76080	Plug	2	
13	58860	Washer: AN970-4	2	
14	56535	Screw: AN501A-428-12	2	
15	52625	Bolt: AN6-34	2	
	54450	Castle Nut: AN310-6	2	
	58790	Washer: AN960-616	2	
	55750	Cotter Pin: AN380-3-3	2	
16	62989	Shock Ring: 1280HD	4	
17	2-1000-012	Block, Bumper	2	
18	40035	Hose Assembly	2	
19	35715-501	Reservoir Assembly	2	
	50359-001	Elbow	2	
20	58289	Plug: AN913-1D	2	
21	62850	Master Cylinder, Cleveland 10-19	2	
22	57940	Elbow, 45°: AN823-4D	2	
23	58054	Fitting, Bulkhead: AN837-4D	2	
	58390	Nut, Bulkhead: AN924-4D	2	
24	51975	Bolt: AN5-30	2	
	54425	Castle Nut: AN310-5	2	
	58780	Washer: AN960-516	4	
	55675	Cotter Pin: AN380-2-2	2	
25	2-1003-027	Fairing, Belly Inboard L H	1	
	2-1003-028	Fairing, Belly Inboard R H	1	
26	2-1003-025	Fairing, Belly Outboard L H	1	
	2-1003-026	Fairing, Belly Outboard R H	1	
27	2-1003-023	Fairing, Gear Leg L H	1	
	2-1003-024	Fairing, Gear Leg R H	1	
28	2-1003-021	Fairing, Gear Leg L H	1	
	2-1003-022	Fairing, Gear Leg R H	1	
29	63950	Tail Wheel Assembly: Maule SFSA-1-4	1	
30	52875	Bolt: AN7-13	1	
	54475	Castle Nut: AN310-7	1	
	55750	Cotter Pin: AN380-3-3	1	
	58800	Washer: AN960-716	1	
31	63015	Spring, Tailwheel (with chain)	1 pr	
32	62950	Yoke: Scott 1140	1 ea	
33	51126	Bolt: AN4-17A	2	
	55400	Nut: AN365-428A	2	
34	2-2253-001	Clamp Assembly	1	
35	52450	Bolt: AN6-22	1	
	54450	Castle Nut: AN310-6	1	

REV 8-22-88

FIGURE 12: LANDING GEAR INSTALLATION

ITEM	PART NUMBER	DESCRIPTION	QTY	SERIAL NO.'S AFFECTED
	58790	Nut: AN960-616	2	
36	76082	Spring Assembly	1	
37	2-2304-001	Fairing, Landing Gear L H	1	
	2-2304-002	Fairing, Landing Gear R H	1	
	2-2304-003	Filler, Foam	2	
38	2-1003-073	Fairing, Brake L H	1	
	2-1003-074	Fairing, Brake R H	1	



FIGURE 13
ENGINE INSTALLATION

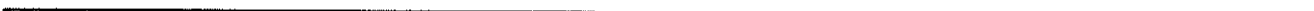

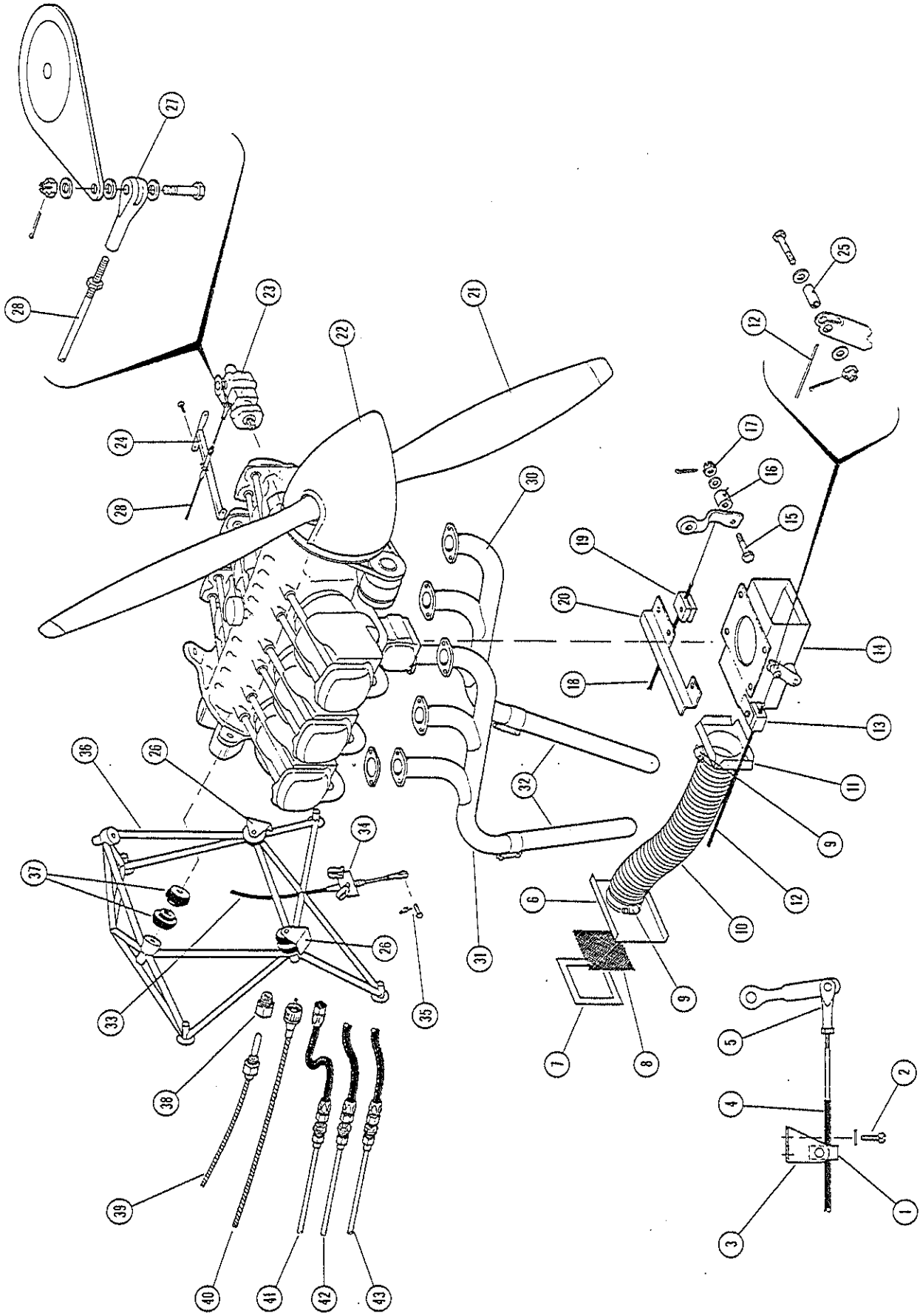

FIGURE 13: ENGINE INSTALLATION

FIGURE 13: ENGINE INSTALLATION

ITEM	PART NUMBER	DESCRIPTION	QTY	SERIAL NO. S AFFECTED
1	79400	Clamp	1	
2	56526	Screw: AN500A-416-10	2	
	58860	Washer: AN970-4	2	
3	2-9000-005	Bracket, Throttle Control	1	
4	60526	Cable, Throttle	1	
5	56940	Terminal, Tie Rod: AN665-21R	1	
	50100	Bolt: AN3-10	1	
	58740	Washer: AN960-10	3	
	54375	Castle Nut: AN310-3	1	
	56675	Cotter Pin: AN380-2-2	1	
6	2-9000-042	Intake Plate Assembly	1	
7	2-9000-040	Plate, Cover	1	
8	2-9000-039	Screen, Intake	1	
9	60840	Clamp	2	
10	2-9000-044	Hose, Intake	1	
11	2-9000-038	Adapter Assembly	1	
12	60536	Cable, Alternate Air	1	
13	79450	Clamp	1	
14	2-6112-001	Heat Box Assembly	1	
15	50996	Bolt: AN4-11	1	
16	2-9000-017	Bushing, Mixture	1	
17	54400	Castle Nut: AN310-4	1	
	55675	Cotter Pin: AN380-2-2	1	
	58760	Washer: AN960-416	2	
18	60537	Cable, Mixture	1	
19	79450	Clamp	1	
20	2-9000-007	Bracket, Mixture Control	1	
21	62540	Propeller: Hartzell #81HC-C2YR-4CF/FC8477-4	1	
22	62995	Spinner: Hartzell #82A0836-60	1	
23	61559	Governor: Hartzell #F-6-31	1	
24	2-7504-011	Bracket, Governor Cable	1	
	56850	Screw: AN526-1032-R8	2	
	58740	Washer: AN960-10	2	
	55392	Nut: AN365-1032C	2	
25	2-9000-019	Bushing, Alternate Air	1	
	50075	Bolt: AN3-7	1	
	58740	Washer: AN960-10	2	
	54375	Castle Nut: AN310-3	1	
	55675	Pin, Cotter: AN380-2-2	1	
26	2-9000-028	Shield, Heat	2	
27	56940	Terminal, Tie Rod: AN665-21R	1	
	50075	Bolt: AN3-7	1	
	58740	Washer: AN960-10	3	
	54375	Castle Nut: AN310-3	1	
	55675	Pin, Cotter: AN380-2-2	1	
28	60648	Cable, Governor	1	
29	2-9000-023	Line, Manifold Pressure	1	
	58010	Union, Bulkhead: AN832-3D	1	
	58790	Washer: AN960-616	2	
	58380	Nut, Bulkhead: AN924-3D	1	
	40032	Hose Assembly: AQ359-3D-0160	1	
	57938	Elbow: AN823-3D	1	
30	2-9004-001	Manifold, Exhaust L H	1	
31	2-9004-002	Manifold, Exhaust R H	1	
32	2-9004-003	Tailpipe, Exhaust	2	
33	60534	Cable, Cowl Flap	1	

FIGURE 13: ENGINE INSTALLATION

ITEM	PART NUMBER	DESCRIPTION	QTY	SERIAL NO'S AFFECTED
34	2-9000-027	Bracket	1	
35	55975	Pin, Clevis: AN393-11	1	
	56075	Safety Pin: AN416-1	1	
36	2-7115-001	Engine Mount Assembly	1	
37	62262	Mount, Lord	8	
	2-9000-003	Bushing	4	
	53073	Bolt: AN8-53A	4	
	55526	Nut: AN365-820	4	
	58805	Washer: AN960-816	4	
38	2-6503-005	Adapter, Oil Temp	1	
	58150	Gasket: AN900-10	1	
39	-	Oil Temperature Bulb & Line (furnished with gauge)	1	
40	2-7000-015	Cable Assembly, Tachometer (aft)	1	
	2-7000-016	Cable Assembly, Tachometer (forward)	1	
	63370	Key, Tach Drive Adapter	1	
	63378	Drive, Dual Tachometer	1	
41	2-6505-035	Aluminum Tube, Fuel Flow	1	
	58010	Union, Bulkhead: AN823-3D	1	
	58790	Washer: AN960-616	2	
	58380	Nut, Bulkhead: AN924-3D	1	
	40021	Hose Assembly: AQ350-3-0380	1	
	57595	Nipple (furnished with engine)	1	
42	2-9009-031	Line, Oil Pressure Gauge	1	
	58020	Union, Bulkhead: AN832-4D	1	
	58800	Washer: AN960-716	2	
	58390	Nut, Bulkhead: AN924-4D	1	
	40022	Hose Assembly: AQ350-4-0120	1	
	57605	Nipple: AN816-4D	1	
	2-6009-024	Restrictor, Oil Line	1	

FIGURE 14
ENGINE BAFFLES

FIGURE 14: ENGINE Baffles

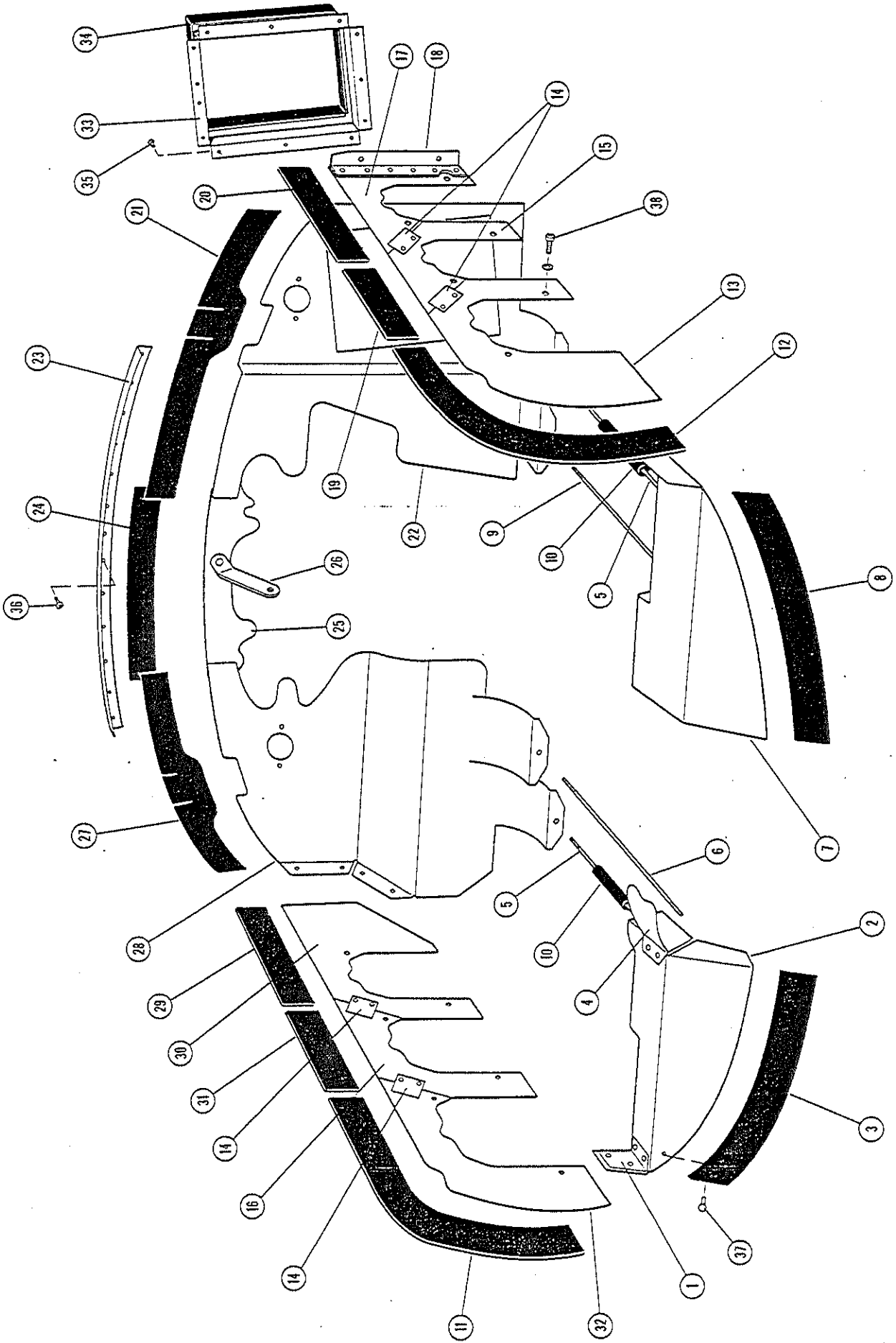

FIGURE 14: ENGINE Baffles

ITEM	PART NUMBER	DESCRIPTION	QTY	SERIAL NO.'S AFFECTED
1	2-9301-065	Angle, Baffle Support	1	
2	2-9301-015	Baffle, Right Front	1	
3	2-9301-055	Seal, Baffle	1	
4	2-9301-025	Baffle, Center Front R H	1	
5	79983	Tie Rod (18-1/2 inches)	2	
6	79979	Tie Rod (16-1/4 inches)	1	
7	2-9301-017	Baffle, Left Front	1	
8	2-9301-057	Seal, Baffle	1	
9	79981	Tie Rod (17-1/2 inches)	1	
10	2-9301-035	Hose, Baffle Tie Rod	4	
11	2-9301-049	Seal, Baffle	1	
12	2-9301-043	Seal, Baffle	1	
13	2-9301-003	Baffle, Side Front L H	1	
14	2-9301-041	Clip, Baffle	8	
15	2-9301-005	Baffle, Side Middle L H	1	
16	2-9301-011	Baffle, Side Middle R H	1	
17	2-9301-072	Baffle Assembly, Side Rear L H	1	
18	2-9301-070	Angle, Baffle	1	
19	2-9301-045	Seal, Baffle	1	
20	2-9301-047	Seal, Baffle	1	
21	2-9301-059	Seal, Baffle	1	
22	2-9301-071	Baffle Assembly Left Rear	1	
23	2-9301-037	Angle, Baffle	1	
24	2-9301-063	Seal, Baffle	1	
25	2-9301-023	Baffle, center Rear	1	
26	2-9301-027	Brace, Baffle	1	
27	2-9301-061	Seal, Baffle	1	
28	2-9301-021	Baffle, Right Rear	1	
29	2-9301-053	Seal, Baffle	1	
30	2-9301-013	Baffle, Side Rear R H	1	
31	2-9301-051	Seal, Baffle	1	
32	2-9301-009	Baffle, Side Front R H	1	
33	2-9301-073	Channel, Baffle	1	
34	2-9301-074	Seal, Baffle	1	
35	56085	Rivet: AN426AD4-4	13	
36	56834	Screw: AN526-832-R7	13	
	55550	Nut: AN365-832A	13	
37	56482	Rivet: AN470A5-5	90	
38	56526	Screw: AN500A-416-R10	12	
	58650	Washer, Tooth Locking: AN936-A416	12	

This page
intentionally blank.



FIGURE 15
GOWLING INSTALLATION



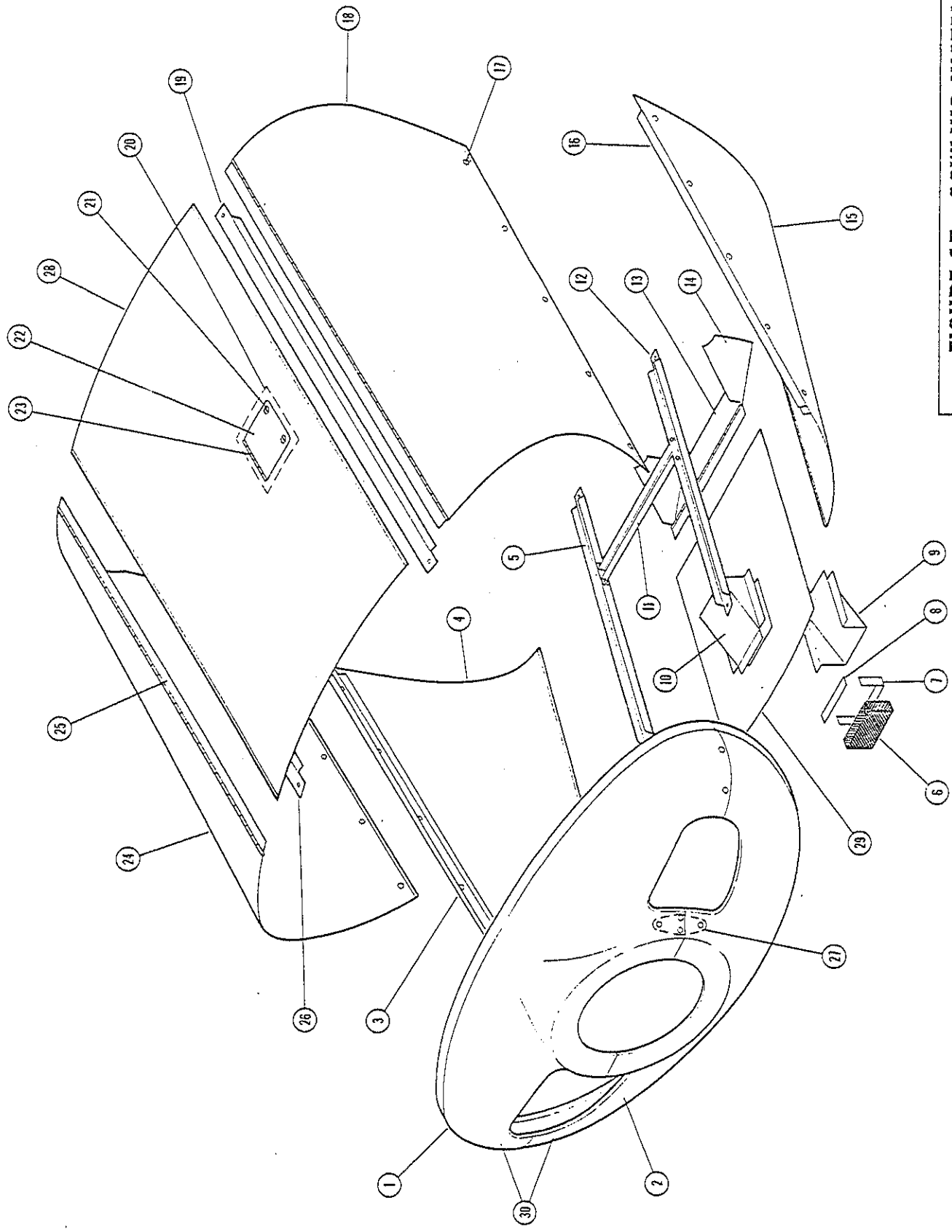

FIGURE 15: COWLING INSTALLATION

FIGURE 15: COWLING INSTALLATION

ITEM	PART NUMBER	DESCRIPTION	QTY	SERIAL NO'S AFFECTED
1	2-6010-007	Nose Bowl, Upper	1	
2	2-6010-005	Nose Bowl, Lower	1	
3	2-9006-012	Channel, Side R H	1	
4	2-9006-054	Cowl, Side R H	1	
5	2-9006-044	Channel, Lower R H	1	
6	2-9006-039	Screen	1	
7	2-9006-021	Retainer, Engine Cowl	1	
8	2-9006-019	Retainer, Engine Cowl	1	
9	2-9006-031	Inlet, Outer	1	
10	2-9006-033	Inlet, Inner	1	
11	2-9006-041	Channel	1	
12	2-9006-043	Channel, Lower L H	1	
13	2-9006-023	Cowl Flap	1	
14	2-9006-045	Plate, Cowl Flap L H	1	
	2-9006-046	Plate, Cowl Flap R H	1	
15	2-9006-053	Cowl, Side L H	1	
16	2-9006-011	Channel, Side L H	1	
17	63314	Stud, Camloc	10	
	62643	Grommet, Camloc	10	
18	2-9006-007	Cowl Door, L H	1	
19	2-9006-009	Channel, Upper L H	1	
20	2-9006-015	Doubler, Oil Door	1	
21	62610	Recepticle, Camloc	2	
	63325	Stud, Camloc	2	
	62545	Washer, Camloc Retainer	2	
22	2-9006-013	Door, Oil Access	1	
23	2-9006-047	Hinge, Oil Access Door	1	
24	2-9006-008	Cowl Door, R H	1	
25	2-9006-051	Hinge, Cowl Door	2	
26	2-9006-010	Channel, Upper R H	1	
27	2-6010-013	Plate, Nose Bowl	2	
	56855	Screw: AN526-1032-R9	8	
	58740	Washer: AN960-10	8	
	55392	Nut: AN365-1032C	8	
28	2-9006-003	Upper Cowl	1	
29	2-9006-005	Cowl, Lower Engine	1	
30	2-6010-015	Nose Bowl Assembly	1	



This page
intentionally blank.





FIGURE 16
OIL SYSTEM INSTALLATION

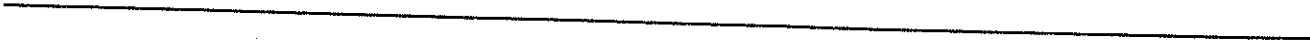

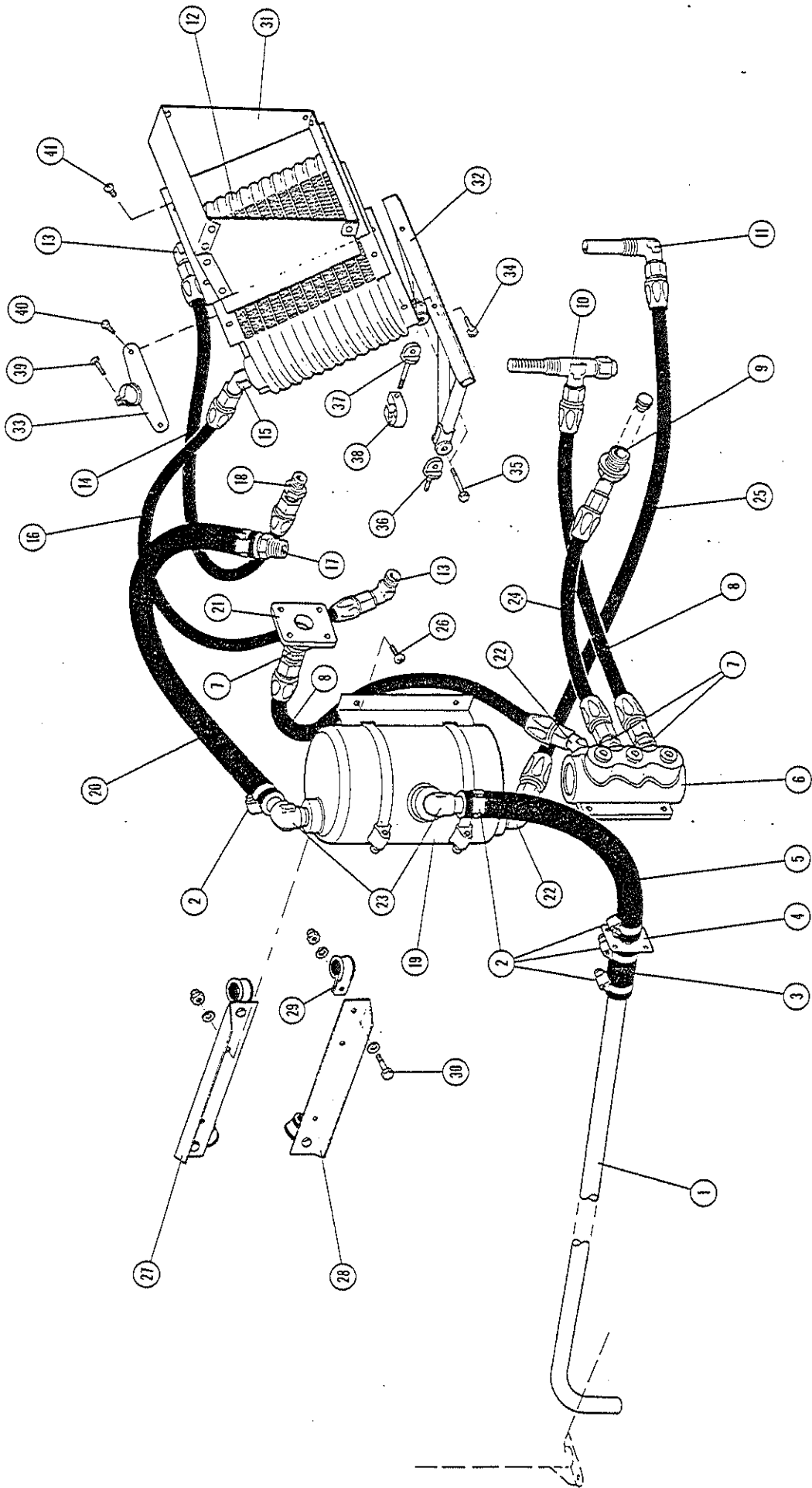

FIGURE 16: OIL SYSTEM INSTALLATION

FIGURE 16: OIL SYSTEM INSTALLATION

ITEM	PART NUMBER	DESCRIPTION	QTY	SERIAL NO'S AFFECTED
1	2-2275-001	Tube, Oil Breather	1	
2	60812	Clamp	6	
3	2-9009-038	Hose, Vent	1	
4	2-7009-020	Fitting, Firewall	1	
5	2-9009-007	Hose	1	
6	-	Inverted Oil Valve (furnished with engine)	1	
7	57650	Nipple: AN816-10D	3	
8	40099	Hose Assembly	2	
9	-	Sump, Fitting (furnished with engine)	1	
10	-	Oil Sump Strainer Fitting (furnished with engine)	1	
	57748	Cap: AN820-10D	1	
11	-	Oil Return Sump Fitting (furnished with engine)	1	
12	61075	Oil Cooler	1	
13	57920	Elbow, 90°: AN822-8D	2	
14	40068	Hose Assembly	1	
15	57960	Elbow, 45°: AN823-8D	1	
16	40071	Hose Assembly	1	
17	58060	Nipple: AN840-12D	1	
18	57640	Nipple: AN816-8D	1	
19	-	Oil Separator (furnished with engine)	1	
20	2-9009-009	Hose	1	
21	60000	Adapter, Oil Pick-up	1	
22	57964	Elbow: AN823-10D	1	
23	58080	Elbow: AN842-12D	2	
24	40095	Hose Assembly	1	
25	40102	Hose Assembly	1	
26	56850	Screw: AN526-1032-R8	4	
	58740	Washer: AN960-10	4	
	55392	Nut: AN365-1032C	4	
27	2-9009-012	Angle	1	
28	2-9009-011	Angle	1	
29	57441	Clamp, Cushioned: AN742-D14C	4	
30	50026	Bolt: AN3-5A	4	
	58740	Washer: AN960-10	8	
	55392	Nut: AN365-1032C	4	
31	2-9009-501	Oil Cooler Duct Assembly	1	
32	2-9009-044	Oil Cooler Bracket Assembly	1	
33	2-9009-046	Oil Cooler Bracket Assembly	1	
34	50101	Bolt: AN3-10A	2	
	58740	Washer: AN960-10	4	
	55392	Nut: AN365-1032C	2	
35	50026	Bolt: AN3-5A	2	
	58740	Washer: AN960-10	2	
	55392	Nut: AN365-1032C	2	
36	53404	Eye Bolt: AN42B-4A	1	
	58740	Washer: AN960-10	1	
	55392	Nut: AN365-1032C	1	
37	53412	Eye Bolt: AN42B-12A	1	
	58740	Washer: AN960-10	1	
	55392	Nut: AN365-1032C	2	
38	60852	Clamp: Umpco S-126-JJ-12	1	
39	50902	Bolt: AN4-7A	1	
	58760	Washer: AN960-416	1	
	55400	Nut: AN365-428A	1	
40	50003	Bolt: AN3-4A	2	
	58740	Washer: AN960-10	2	

FIGURE 16: OIL SYSTEM INSTALLATION

ITEM	PART NUMBER	DESCRIPTION	QTY	SERIAL NO.'S AFFECTED
41	55392	Nut: AN365-1032C	2	
	56850	Screw: AN526-1032-R8	4	
	58740	Washer: AN960-10	4	
	55392	Nut: AN365-1032C	4	



FIGURE 17
FUEL SYSTEM INSTALLATION

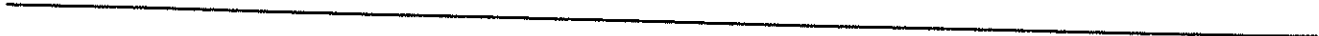

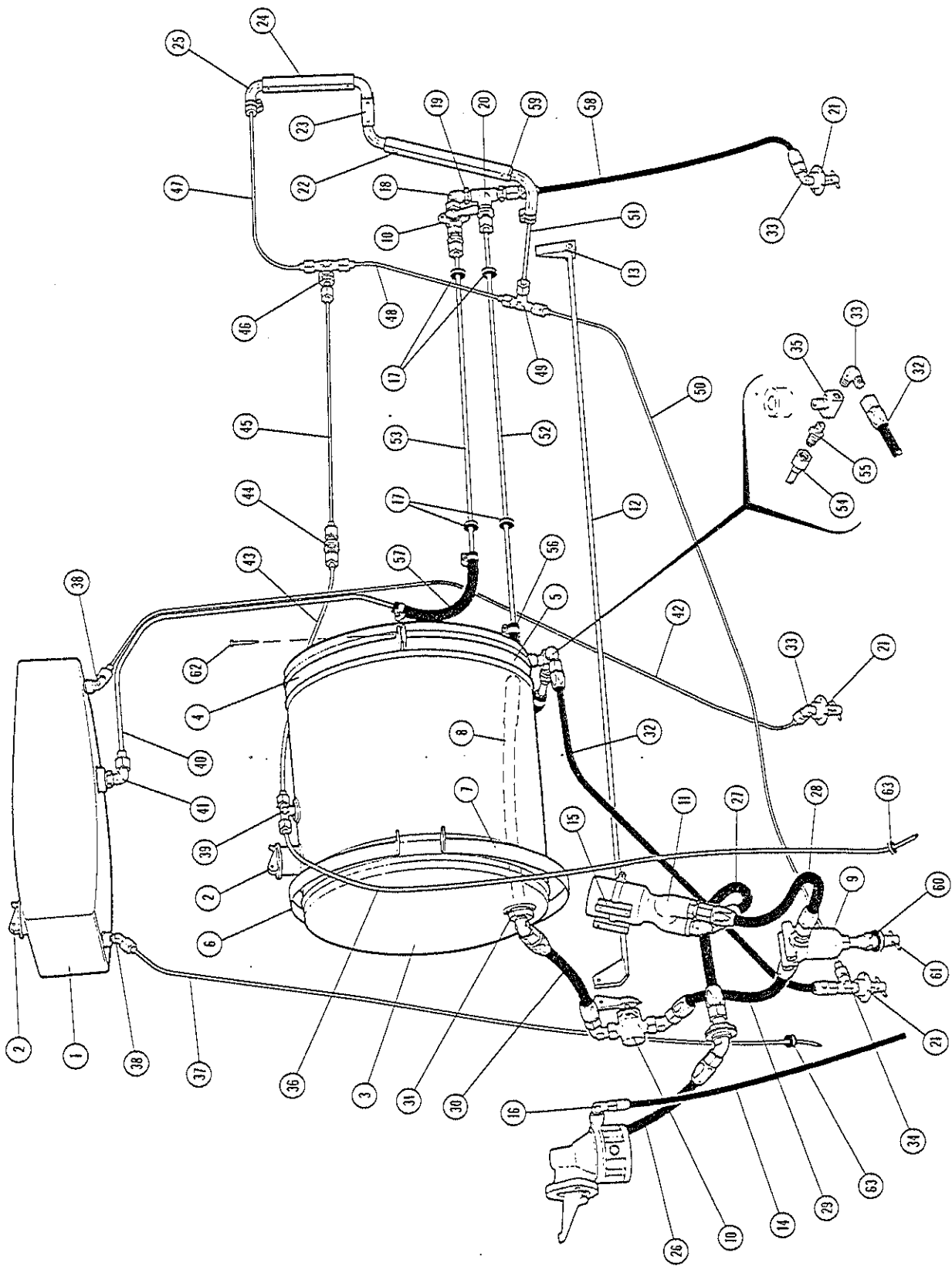

FIGURE 17: FUEL SYSTEM INSTALLATION

FIGURE 17: FUEL SYSTEM INSTALLATION

ITEM	PART NUMBER	DESCRIPTION	QTY	SERIAL NO.'S AFFECTED
1	2-1020-003	Tank, Centersection (upper wing)	1	
2	61424	Cap, Fuel Tank	2	
3	2-6501-000	Fuel Tank Assembly (fuselage)	1	
4	2-6501-016	Strap, Fuel Tank	1	
5	2-6501-018	Strap, Fuel Tank	1	
6	2-6501-017	Strap, Fuel Tank	1	
7	2-6501-019	Strap, Fuel Tank	1	
8	2-6502-003	Flop Tube Assembly	1	
9	2-6500-026	Strainer, Fuel	1	
	51401	Bolt: AN4-31A	2	
	55400	Nut: AN365-428A	2	
10	63920	Valve, Shut-Off	2	
11	62545	Pump, Electric Fuel	1	
	2-7602-038	Plug, Vent	1	
12	2-6500-030	Fuel Selector Assembly	1	
13	79348	Pointer	1	
14	40023	Hose Assembly	1	
15	2-7602-033	Bracket, Fuel Pump	1	
	60840	Clamp	1	
	2-7602-034	Pad, Weldon Pump	1	
	50851	Bolt: AN4-5A	4	
	58760	Washer: AN960-416	8	
	55400	Nut: AN365-428A	4	
16	57750	Elbow: AN822-2D	1	
17	58480	Grommet: AN931-7-11	4	
18	58312	Elbow: AN914-2D	1	
19	58230	Nipple: AN911-2D	1	
20	58325	Tee: AN917-2D	1	
21	79349	Washer Assembly	3	
	63926	Valve, Quick Drain	3	
22	2-6510-016	Channel, Fuel Gauge	1	
23	2-6510-015	Channel, Fuel Gauge	1	
24	1-0603-044	Holder, Upper Fuel Gauge	1	
25	2-6510-013	Line, Fuel Indicator	1	
	60860	Clamp	2	
26	40054	Hose Assembly	1	
	57615	Nipple: AN816-6D	1	
	58055	Elbow: AN837-6	1	
	58400	Nut: AN924-6D	1	
	65941	O-Ring: MS29512-6	1	
27	40048	Hose Assembly	1	
	58056	Elbow: AN837-6D	1	
28	40054	Hose Assembly	1	
	57570	Union: AN815-6D	1	
	65941	O-Ring: MS29512-6	2	
29	40054	Hose Assembly	1	
	57570	Union: AN815-6D	1	
	65941	O-Ring: MS29512-6	2	
	57950	Elbow: AN823-6D	1	
30	40054	Hose Assembly	1	
	57800	Elbow: AN822-6D	2	
31	2-6502-004	Bushing, Flop Tube	1	
32	40042	Hose Assembly	1	
33	57770	Elbow: AN822-4D	3	
34	57976	Tee: AN826-4D	1	
35	61493	Tee, Tubing	1	

FIGURE 17: FUEL SYSTEM

ITEM	PART NUMBER	DESCRIPTION	QTY	SERIAL NO'S AFFECTED
36	2-6500-003	Line, Fuel Vent	1	
37	2-6510-028	Line, Fuel Vent	1	
38	57940	Elbow: AN823-4D	2	
39	57971	Tee: AN825-4D	1	
40	2-6510-026	Line, Fuel	1	
41	57800	Elbow: AN822-6D	1	
	58282	Bushing: AN912-9D	1	
42	2-6510-030	Line, Drain	1	
43	2-6510-010	Line, Fuel	1	
44	58020	Union: AN832-4D	1	
	58390	Nut: AN924-4D	1	
45	2-6510-011	Line, Fuel	1	
46	58045	Tee: AN834-4D	1	
	58390	Nut: AN924-4D	1	
47	2-6510-012	Line, Fuel	1	
48	2-6510-020	Line, Fuel Vent	1	
49	57967	Tee: AN824-4D	1	
50	2-6510-019	Line, Fuel	1	
51	2-6510-018	Line, Fuel	1	
52	2-6510-023	Line, Fuel	1	
	57615	Nipple: AN816-6D	1	
53	2-6510-022	Line, Fuel	1	
	57615	Nipple: AN816-6D	1	
54	2-6510-027	Line, Fuel	1	
55	57620	Nipple: AN816-6-2D	1	
56	2-6510-024	Hose, Fuel	1	
	60860	Clamp	2	
57	2-6510-025	Hose, Fuel	1	
	60860	Clamp	2	
58	40027	Hose Assembly	1	
59	57605	Nipple: AN816-4D	1	
60	61492	Fitting, Tubing	1	
61	63926	Valve, Quick Drain	1	
	58525	Grommet: AN931-10-14	1	
62	51151	Boit: AN4-20A	4	
	55400	Nut: AN365-428A	4	
	58760	Washer: AN960-416	8	
63	58450	Grommet: AN931-4-7	2	



FIGURE 18
INSTRUMENTS & PLACARDS

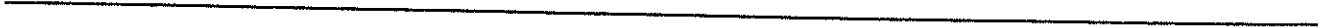

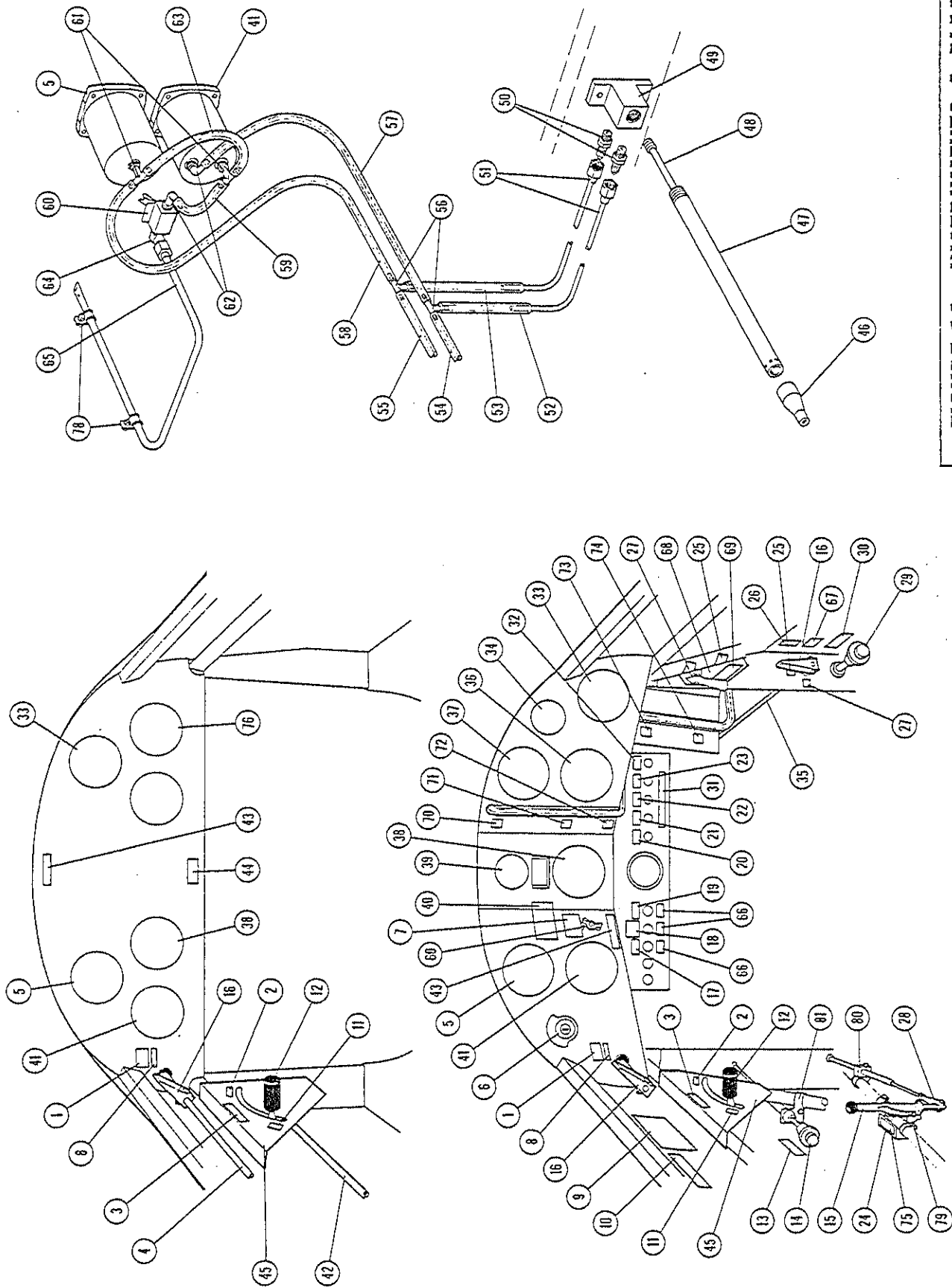

FIGURE 18: INSTRUMENTS & PLACARDS

FIGURE 18: INSTRUMENTS & PLACARDS

ITEM	PART NUMBER	DESCRIPTION	QTY	SERIAL NO'S AFFECTED
1	75036	Placard, High RPM	2	
2	75021	Placard, Open	2	
3	75028	Placard, Throttle	2	
4	2-7000-013	Tube, Propeller Governor Control	1	
	2-7000-004	Clamp, Tube	1	
	60873	Clip, Fairlead	1	
	61300	Fairlead (two makes one assembly)	2	
5	61786	Altimeter	2	
6	63335	Switch, Ignition: Bendix 10-357200-1	1	
	61106	Plate, Dial Switch	1	
7	75032	Placard, Alternate Static	1	
8	75035	Placard, Unlock	2	
9	75027	Placard, Operation Limitations	1	
10	75034	Placard, Acrobatic maneuvers Approved	1	
11	75020	Placard, Closed	2	
12	62107	Knob, Throttle	2	
	1-0510-069	Throttle Lever Assembly	2	
13	75018	Placard, Mixture	1	
14	60537	Cable, Control (mixture)	1	
15	60150	Control, Cowl Flap	1	
16	79348	Pointer, Fuel Selector	3	
17	75002	Placard, Boost Pump	1	
18	75003	Placard, Alternator Field	1	
19	75004	Placard, Master Switch	1	
20	75005	Placard, Alternator	1	
21	75006	Placard, Alternator Field	1	
22	75007	Placard, Boost Pump	1	
23	75008	Placard, Radio	1	
24	2-7504-013	Bracket, Cowl Flap Index	1	
	50151	Bolt: AN3-12A	2	
	58740	Washer: AN960-10	2	
	55601	Nut: AN365-1032A	2	
25	75011	Placard, On	1	
26	75013	Placard, Fuel Selector	1	
27	75012	Placard, Off	2	
28	56940	Terminal, Tie Rod	1	
	54548	Nut: AN315-3R	1	
	55975	Pin, Clevis: AN393-11	1	
	55675	Pin, Cotter: AN380-2-2	1	
29	62108	Knob, Alternate Air (black)	1	
30	75019	Placard, Pull for Alternate Air	1	
31	75010	Placard, Circuit Breakers	1	
32	75033	Placard, Stall Warn	1	
33	61892	Tachometer	2	
34	61652	Horn, Stall Warning	1	
35	2-6500-030	Tube Assembly, Fuel Selector	1	
36	61943	Gauge, Oil Pressure/Oil Temperature	1	
37	61932	Gauge, Manifold and Fuel Pressure	1	
38	61950	G-Meter	2	
39	61675	Compass, Magnetic: C-2300	1	
40	75031	Placard, Maneuver Speed	1	
41	61678	Indicator, Airspeed	2	
42	2-2247-003	Throttle Rod Assembly	1	
43	75030	Placard, No Smoking	1	
44	75023	Placard, Solo Rear Seat Only	1	
45	2-2226-001	Plate, Rear Throttle	1	

FIGURE 18: INSTRUMENTS & PLACARDS INSTALLATION

ITEM	PART NUMBER	DESCRIPTION	QTY	SERIAL NO'S AFFECTED
	2-2226-002	Plate, Front Throttle	1	
46	77043	Nut, Pitot Tube	1	
47	77044	Tube, Static	1	
48	2-4329-002	Tube, Pitot	1	
49	77035	Box, Junction	1	
50	57595	Nipple: AN816-3D	2	
51	2-4125-002	Line, Pitot	1	
	2-4125-003	Line, Static	1	
52	2-4125-004	Line, Pitot	1	
53	2-4125-005	Line, Static	1	
54	2-4125-006	Line, Pitot	1	
55	2-4125-007	Line, Static	1	
56	49563	Tee	2	
57	2-4125-008	Line, Pitot	1	
58	2-4125-009	Line, Static	1	
59	2-4125-014	Line, Alternate Static	1	
60	2-4125-017	Valve, Alternate Air	1	
61	49556	Tee	2	
62	49529	Elbow	2	
63	2-4125-011	Line, Static	1	
64	57760	Elbow: AN822-3D	1	
65	2-4125-015	Tube, Alternate Static	1	
66	75009	Placard, Off	3	
67	75029	Placard, Usable Fuel	2	
68	2-6510-021	Bracket, Fuel Valve	1	
69	75056	Placard, Transfer Aux Fuel	1	
70	75119	Placard, Fuel Indicator	1	
71	-	3/4 cut from 75119 Placard	1	
72	-	1/2 cut from 75119 Placard	1	
73	-	1/4 cut from 75119 Placard	1	
74	-	E cut from 75119 Placard	1	
75	75153	Placard, Cowl Flap	1	
76	61726	Gauge, Manifold Pressure	1	
77	75121	Placard, Alternate Static Air Correction	1	
78	57390	Clamp, Cushioned: AN742-D5C	2	
	56833	Screw: AN526-832-R6	2	
	58720	Washer: AN960-8	2	
	55550	Nut: AN365-832A	2	
79	60848	Clamp: Umpco S-126-JJ-8	2	
	50151	Bolt: AN3-12A	2	
	58740	Washer: AN960-10	2	
	55601	Nut: AN365-1032A	2	
80	79400	Bracket	1	
	60848	Clamp: Umpco S-126-JJ-8	1	
	50176	Bolt: AN3-13A	1	
	58740	Washer: AN960-10	1	
	55601	Nut: AN365-1032A	1	
81	2-2126-001	Bracket	1	
	50151	Bolt: AN3-12A	1	
	58740	Washer: AN960-10	1	
	55601	Nut: AN365-1032A	1	

FIGURE 19
TRIM CONTROL SYSTEM

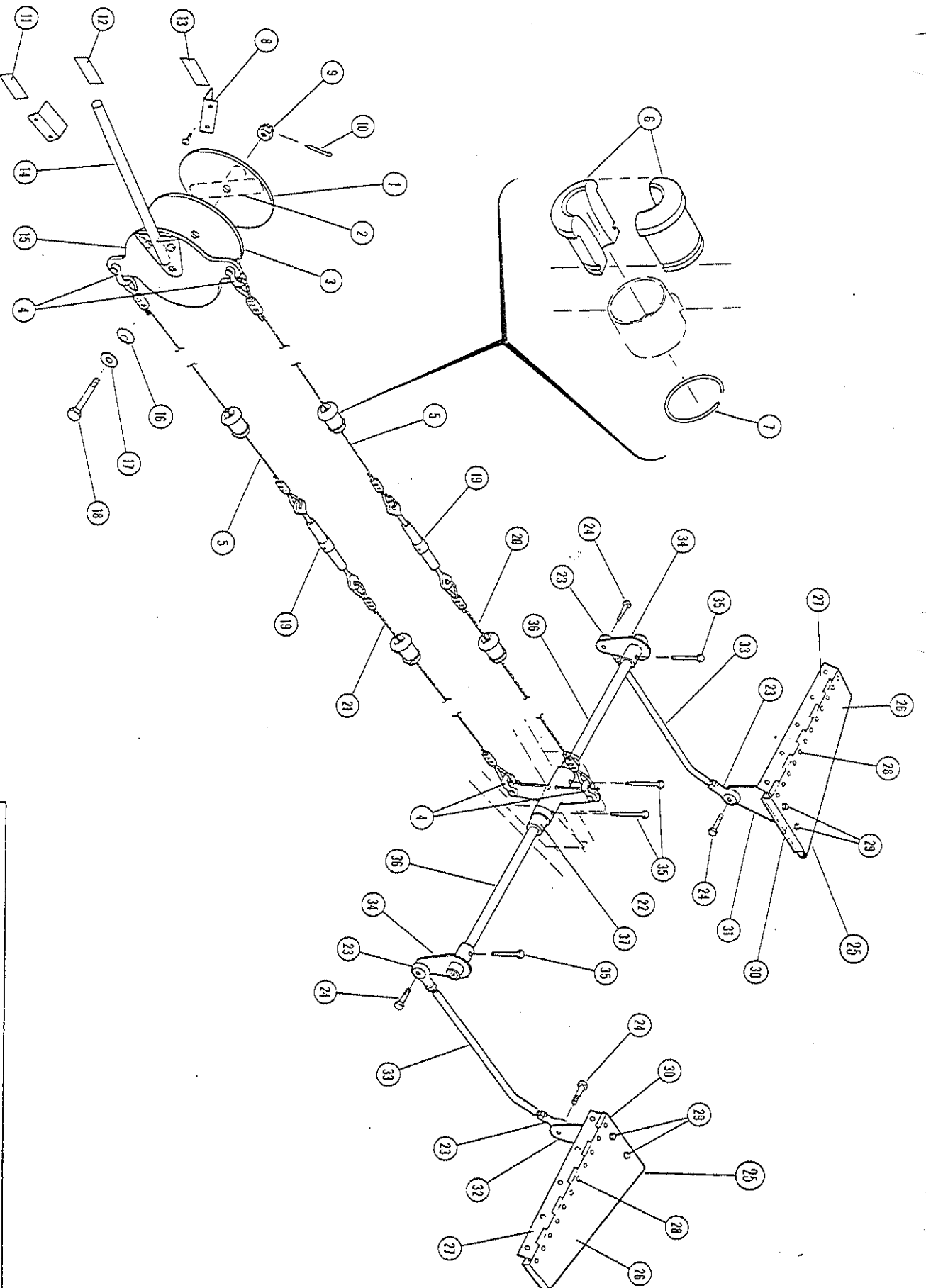

FIGURE 19: TRIM CONTROL SYSTEM

FIGURE 19: TRIM CONTROL SYSTEM

ITEM	PART NUMBER	DESCRIPTION	QTY	SERIAL NO.'S AFFECTED
1	2-2100-129	Plate, Trim Tab	1	
2	2-2124-001	Bushing Assembly, Elevator Trim	1	
3	2-3250-002	Disc, Friction	1	
4	53870	Shackle: AN115-8	2	
	55977	Pin: AN393-13	2	
	55675	Cotter Pin: AN380-2-2	2	
5	2-3150-003	Cable, Forward Trim Tab	2	
6	61300	Fairlead	8	
7	60873	Clip	4	
8	2-2280-005	Bracket, Trim Stop	2	
	56631	Screw: AN526-632-R7	4	
	58700	Washer: AN960-6	4	
	55475	Nut: AN365-632A	4	
9	54400	Castle Nut: AN310-4	1	
10	55675	Cotter Pin: AN380-2-2	1	
11	75017	Placard, Nose Up	1	
12	75016	Placard, Neutral	1	
13	75015	Placard, Nose Down	1	
14	2-5232-000	Handle, Trim Control	1	
	56157	Rivet: AN426-AD6-6	2	
15	2-5232-001	Disc	1	
16	63944	Cone Washer: BO500-025	4	
17	58760	Washer: AN960-416	1	
18	51140	Bolt: AN4-20	1	
19	54076	Turnbuckle: AN155-8S	2	
20	2-3150-004	Cable, Aft Trim Tab	1	
21	2-3150-005	Cable, Aft Trim Tab	1	
22	2-3230-001	Horn Assembly, Tab Actuator	1	
	53870	Shackle: AN115-8	2	
23	60099	Bearing	4	
	54550	Nut: AN315-4	4	
24	50076	Bolt: AN3-7A	4	
	58740	Washer: AN960-10	4	
	55392	Nut: AN365-1032C	4	
25	2-3220-001	Tab, Elevator L H	1	
	2-3220-002	Tab, Elevator R H	1	
26	2-3220-011	Shell, Tab L H	1	
	2-3220-012	Shell, Tab R H	1	
27	2-3220-015	Hinge, Trim Tab L H	1	
	2-3220-016	Hinge, Trim Tab R H	1	
28	56505	Rivet: AN470-AD4-4	10	
29	50076	Bolt: AN3-7A	4	
	58740	Washer: AN960-10	2	
	58750	Washer: AN960-10L	2	
	55392	Nut: AN365-1032C	4	
30	2-3220-017	Spacer	2	
31	2-3220-014	Bracket, Trim Tab R H	1	
32	2-3220-013	Bracket, Trim Tab L H	1	
33	2-5234-001	Control Rod Assembly	2	
34	2-5230-001	Arm Assembly, Trim Tab	2	
35	50126	Bolt: AN3-11A	2	
	58740	Washer: AN960-10	2	
	55392	Nut: AN365-1032C	2	
36	2-5231-003	Shaft, Trim Tab L H	1	
	2-5231-004	Shaft, Trim Tab R H	1	
37	2-3230-013	Tube	1	

REV 8-22-88



This page
intentionally blank.





FIGURE 20
ELEVATOR CONTROL SYSTEM



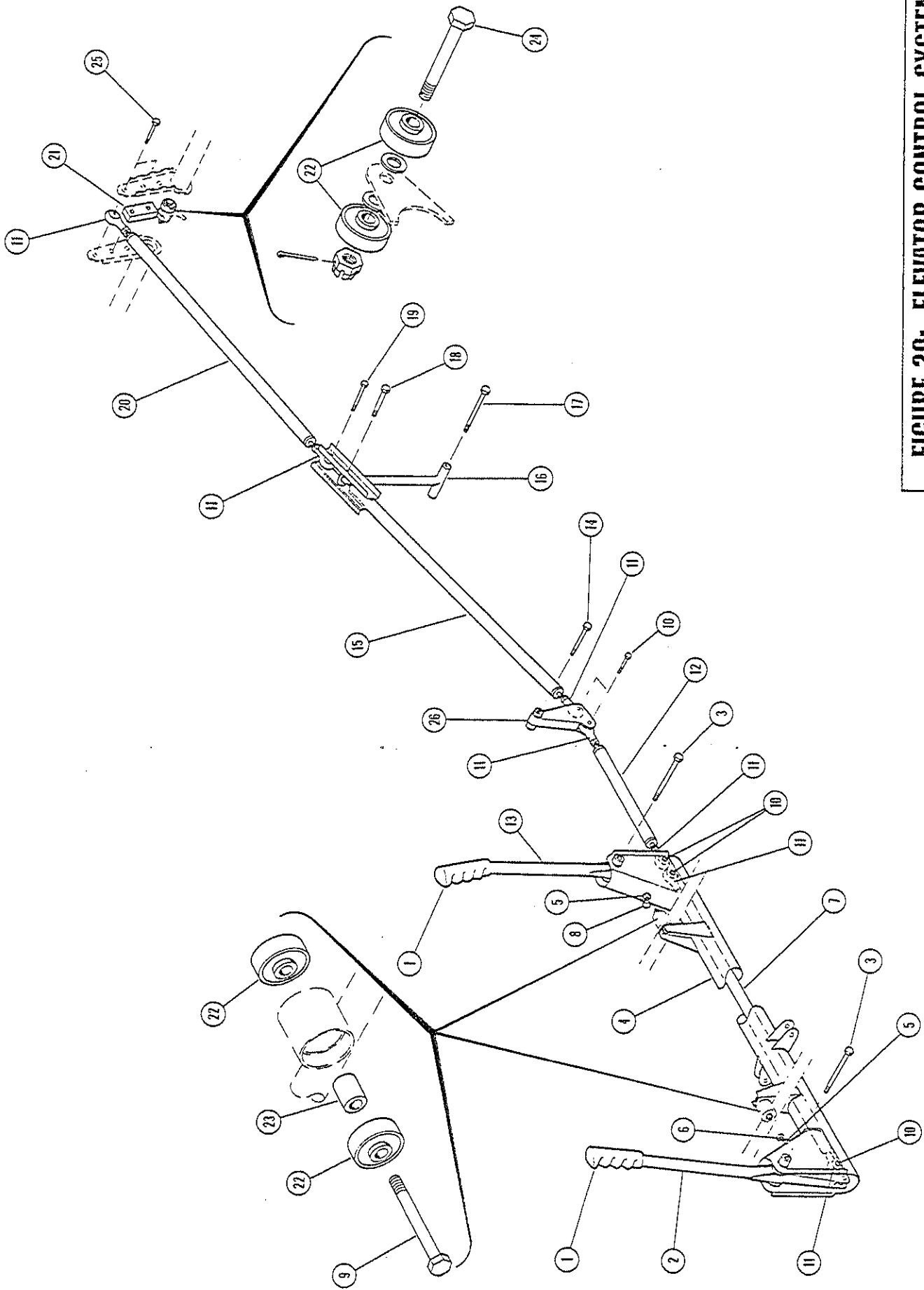

FIGURE 20: ELEVATOR CONTROL SYSTEM

FIGURE 20: ELEVATOR CONTROL SYSTEM

ITEM	PART NUMBER	DESCRIPTION	QTY	SERIAL NO.'S AFFECTED
1	30942-501	Grip, Control Stick	2	
2	2-5110-008	Stick, Forward Control	1	
3	51326	Bolt: AN4-27A	2	
	58760	Washer: AN960-416	4	
	55400	Nut: AN365-428A	2	
4	2-5100-035	Tube Assembly, Cockpit Control	1	
5	54550	Nut: AN315-4	2	
6	77117	Stop Bolt	1	
7	2-5200-10	Control Rod Assembly	1	
8	77119	Stop Bolt	1	
9	51151	Bolt: AN4-20A	2	
	58760	Bolt: AN960-416	2	
	55400	Nut: AN365-428A	2	
10	50101	Bolt: AN3-10A	5	
	58740	Washer: AN960-10	16	
	55392	Nut: AN365-1032C	9	
11	60100	Bearing, Rod End	7	
	54550	Nut: AN315-4	7	
12	2-5200-021	Control Rod Assembly	1	
13	2-5110-006	Stick, Rear Control	1	
14	51175	Bolt: AN4-21	1	
	58760	Washer: AN960-416	3	
	54400	Castle Nut: AN310-4	1	
	55675	Cotter Pin: AN380-2-2	1	
15	2-5210-001	Elevator Control Rod Assembly	1	
16	2-5221-001	Elevator Arm Assembly	1	
17	51200	Bolt: AN4-22	1	
	58760	Washer: AN960-416	3	
	54400	Castle Nut: AN310-4	1	
	55675	Cotter Pin: AN380-2-2	1	
18	51000	Bolt: AN4-13	1	
	58760	Washer: AN960-416	3	
	54400	Castle Nut: AN310-4	1	
	55675	Cotter Pin: AN380-2-2	1	
19	50151	Bolt: AN3-12A	1	
	58740	Washer: AN960-10	2	
	55392	Nut: AN365-1032C	1	
20	2-5200-002	Control Rod Assembly	1	
21	79202	Spacer, Elevator	1	
22	60107	Bearing	6	
23	79320	Spacer, Bearing	2	
24	51075	Bolt: AN4-16	1	
	58760	Washer: AN960-416	2	
	54400	Castle Nut: AN310-4	1	
	55675	Cotter Pin: AN380-2-2	1	
25	50151	Bolt: AN3-12A	3	
	58740	Washer: AN960-10	6	
	55392	Nut: AN365-1032C	3	
26	2-5220	Idler	1	

This page
intentionally blank.



FIGURE 21
AILERON CONTROL SYSTEM

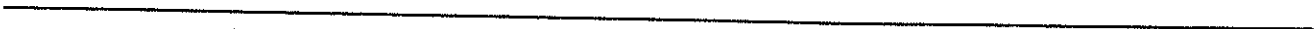

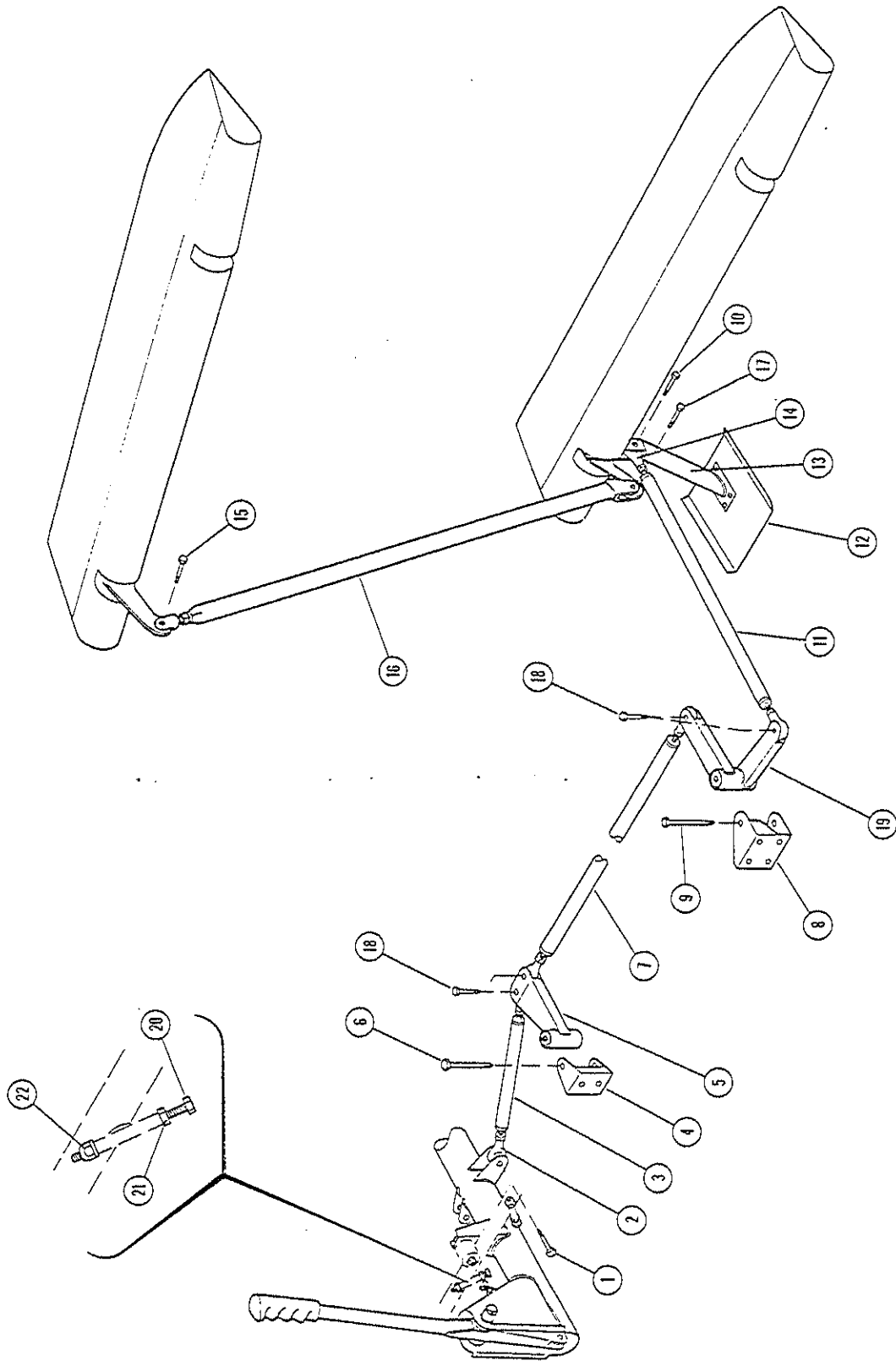

FIGURE 21: AILERON CONTROL SYSTEM

FIGURE 21: AILERON CONTROL SYSTEM

ITEM	PART NUMBER	DESCRIPTION	QTY	SERIAL NO.'S AFFECTED
1	50101	Bolt: AN3-10A	2	
	55392	Nut: AN365-1032C	2	
	58740	Washer: AN960-10	2	
	58750	Washer: AN960-10L	4	
2	60100	Bearing	2	
	54575	Hex Nut: AN315-5	2	
3	2-5200-007	Control Rod Assembly	2	
	60100	Bearing	2	
	54575	Hex Nut: AN315-5	2	
4	2-5330-004	Bracket, Idler Assembly	2	
	50201	Bolt: AN3-14A	4	
	55392	Nut: AN365-1032C	4	
	58740	Washer: AN960-10	4	
	58850	Washer: AN970-3	4	
5	2-5330-002	Control Arm Assembly	2	
6	51151	Bolt: AN4-20A	2	
	55400	Nut: AN365-428A	2	
7	2-5200-008	Control Rod Assembly	2	
	60100	Bearing	4	
	54575	Hex Nut: AN315-5	4	
8	2-5311-003	Bracket, L H Bellcrank	1	
	2-5311-004	Bracket, R H Bellcrank	1	
	50201	Bolt: AN3-14A	8	
	55392	Nut: AN365-1032C	8	
	58740	Washer: AN960-10	8	
9	58850	Washer: AN970-3	8	
	51450	Bolt: AN4-40A	2	
	55400	Nut: AN365-428A	2	
	58760	Washer: AN960-416	2	
10	50076	Bolt: AN3-7A	2	
	55392	Nut: AN365-1032C	2	
	2-5200-009	Control Rod Assembly	2	
12	2-4250-002	Plate, Counter-balance	2	
	56620	Screw: AN526-632-6	8	
	58700	Washer: AN960-6	8	
	55475	Nut: AN365-632A	8	
13	2-4250-010	Counter-balance Arm Assembly	2	
14	60100	Bearing	4	
	54575	Hex Nut: AN315-5	4	
	50076	Bolt: AN3-7A	2	
15	55392	Nut: AN365-1032C	2	
	58740	Washer: AN960-10	4	
	58750	Washer: AN960-10L	4	
	2-5216-016	Aileron Inter-Connect Assembly	2	
16	79325	Fork	2	
	54575	Hex Nut: AN315-5	2	
	50076	Bolt: AN3-7A	2	
17	55392	Nut: AN365-1032C	2	
	58740	Washer: AN960-10	8	
	50076	Bolt: AN3-7A	2	
	55392	Nut: AN365-1032C	2	
18	58740	Washer: AN960-10	8	
	50076	Bolt: AN3-7A	2	
	55392	Nut: AN365-1032C	2	
19	58740	Washer: AN960-10	8	
	2-5313-007	Bellcrank, Aileron L H	1	
20	2-5313-008	Bellcrank, Aileron R H	1	
	79215	Bolt, Aileron Stop	2	

FIGURE 21: AILERON CONTROL SYSTEM

ITEM	PART NUMBER	DESCRIPTION	QTY	SERIAL NO.'S AFFECTED
21	54500	Hex Nut: AN315-4	2	
22	55400	Nut: AN365-428A	2	



FIGURE 22
RUDDER CONTROL SYSTEM



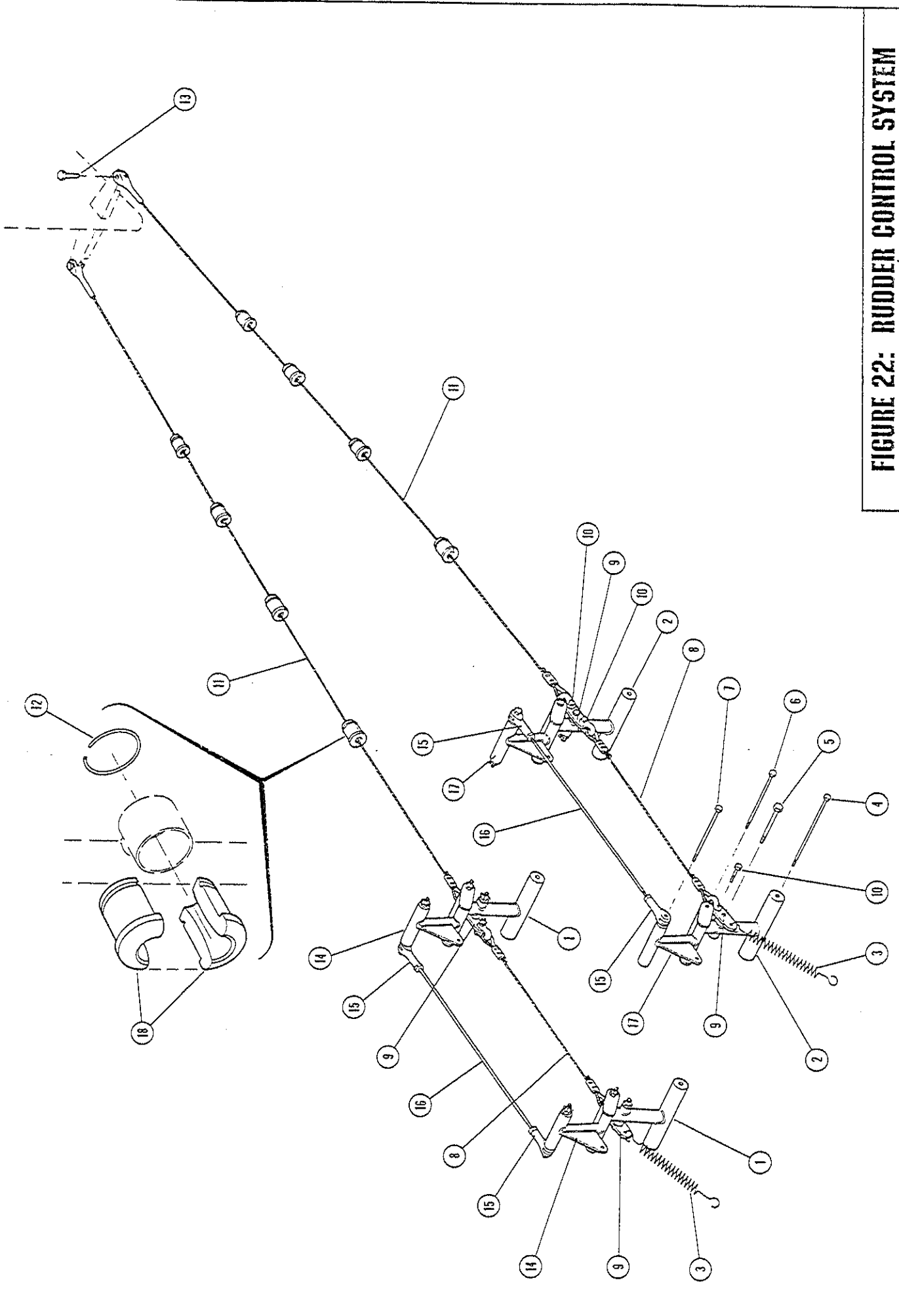

FIGURE 22: RUDDER CONTROL SYSTEM

()

()

()

FIGURE 22: RUDDER CONTROL SYSTEM

ITEM	PART NUMBER	DESCRIPTION	QTY	SERIAL NO.'S AFFECTED
1	2-5310-002	Rudder Pedal Assembly	2	
2	2-5310-002	Rudder Pedal Assembly	2	
3	63009	Spring, Rudder	2	
4	50671	Bolt: AN3-44	4	
	54375	Castle Nut: AN310-3	4	
	58740	Washer: AN960-10	4	
	55675	Cotter Pin: AN380-2-2	4	
5	51140	Bolt: AN4-20	4	
	54400	Castle Nut: AN310-4	4	
	58760	Washer: AN960-416	4	
	55675	Cotter Pin: AN380-2-2	4	
6	50575	Bolt: AN3-41	4	
	54375	Castle Nut: AN310-3	4	
	58740	Washer: AN960-10	4	
	55675	Cotter Pin: AN380-2-2	4	
7	50490	Bolt: AN3-36	4	
	54375	Castle Nut: AN310-3	4	
	58740	Washer: AN960-10	4	
	55675	Cotter Pin: AN380-2-2	4	
8	77010	Cable Assembly, Forward Rudder	2	
9	2-5122-001	Link, Control	4	
10	50025	Bolt: AN3-5	6	
	54375	Castle Nut: AN310-3	6	
	55675	Cotter Pin: AN380-2-2	6	
	58740	Washer: AN960-10	6	
11	77007	Cable Assembly, Aft Rudder	2	
12	60873	Clip, Fairlead	8	
13	58740	Washer: AN960-10	4	
	50050	Bolt: AN3-6	2	
	54375	Castle Nut: AN310-3	2	
	55675	Cotter Pin: AN380-2-2	2	
14	2-5300-002	Brake Pedal Assembly R H	2	
15	56940	Terminal: AN665-21R	4	
16	76100	Brake Rod	2	
	54548	Hex Nut: AN315-3	4	
17	2-5300-001	Brake Pedal Assembly L H	2	
18	61300	Fairlead (two make one assembly)	16	



This page
intentionally blank.





FIGURE 23
ELECTRICAL SYSTEM



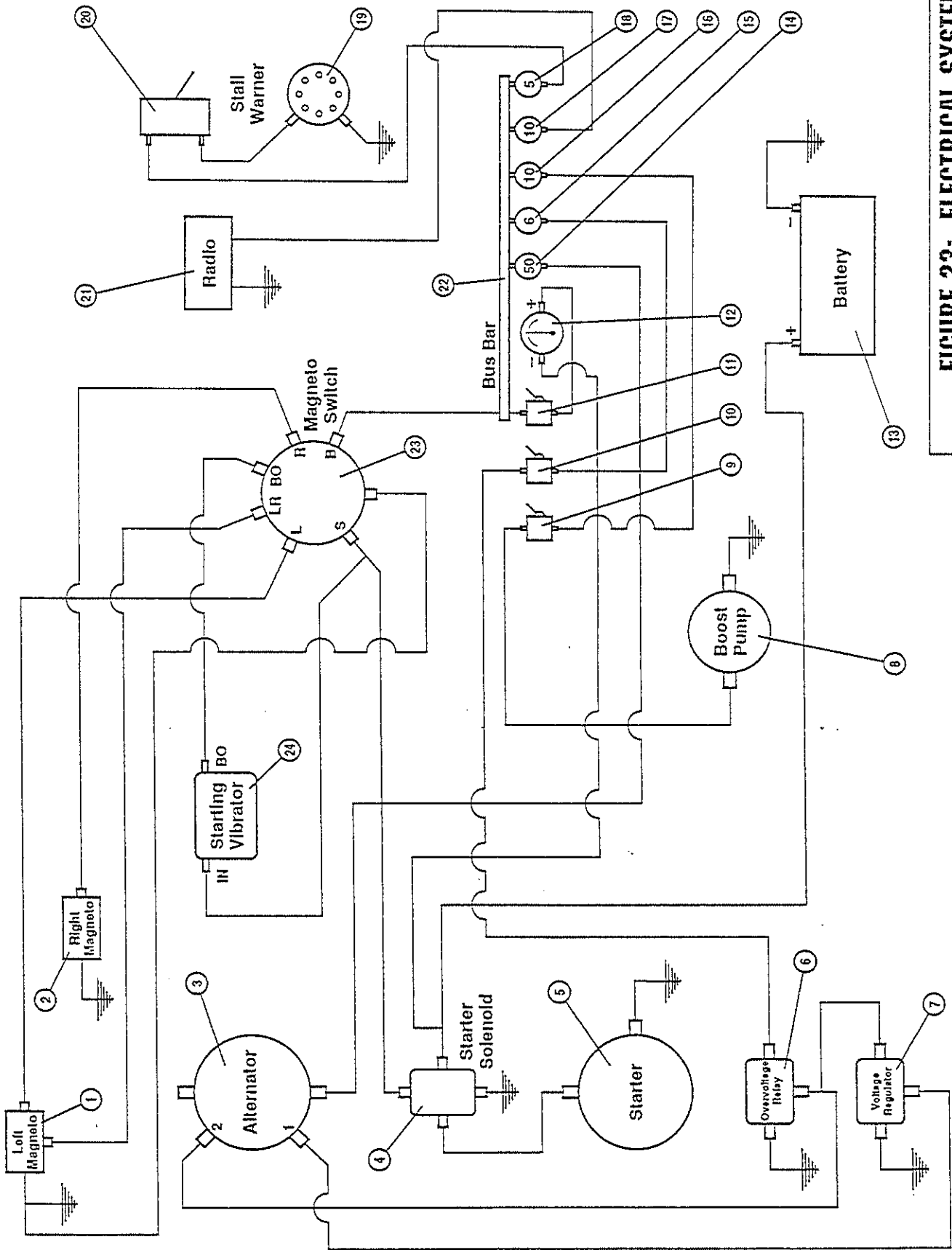

FIGURE 23: ELECTRICAL SYSTEM

FIGURE 23: ELECTRICAL SYSTEM

ITEM	PART NUMBER	DESCRIPTION	QTY	SERIAL NO.'S AFFECTED
1	-	Left Magneto: Bendix Type S6LN-200	1	
2	-	Right Magneto: Bendix Type S6LN-204	1	
3	-	Alternator: Prestolite ALY8420LS	1	
4	63342	Switch, Solenoid	1	
5	61220	Starter, Aircraft Engine: Prestolite MZ4222	1	
6	61215	Relay, Overvoltage: Prestolite FOC4002	1	
7	61230	Regulator, Voltage: VSF-7203A	1	
8	61545	Pump, Electric Fuel	1	
9	63340	Switch: AN3022-2	1	
10	63340	Switch: AN3022-2	1	
11	63340	Switch: AN3022-2	1	
12	61705	Ammeter	1	
13	60065	Battery, Gel-cell: U1-31-3B	1	
	2-2125-021	Battery Support Assembly	1	
14	60450	Breaker, Circuit	1	
15	60442	Breaker, Circuit	1	
16	60445	Breaker, Circuit	1	
17	60445	Breaker, Circuit	1	
18	60440	Breaker, Circuit	1	
19	61652	Horn, Stall Warning	1	
20	61103	Detector, Stall Warning	1	
21	A/R	Radio (option)	1	
22	2-2129-005	Bar, Buss	1	
23	63335	Switch, Ignition: Bendix 10-357200-1	1	
24	63333	Vibrator, Starter: Bendix 10-176487-121	1	

This page
intentionally blank.



FIGURE 24
CANOPY INSTALLATION

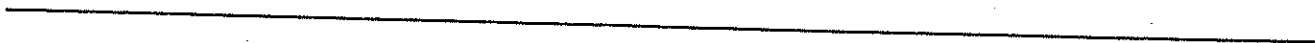

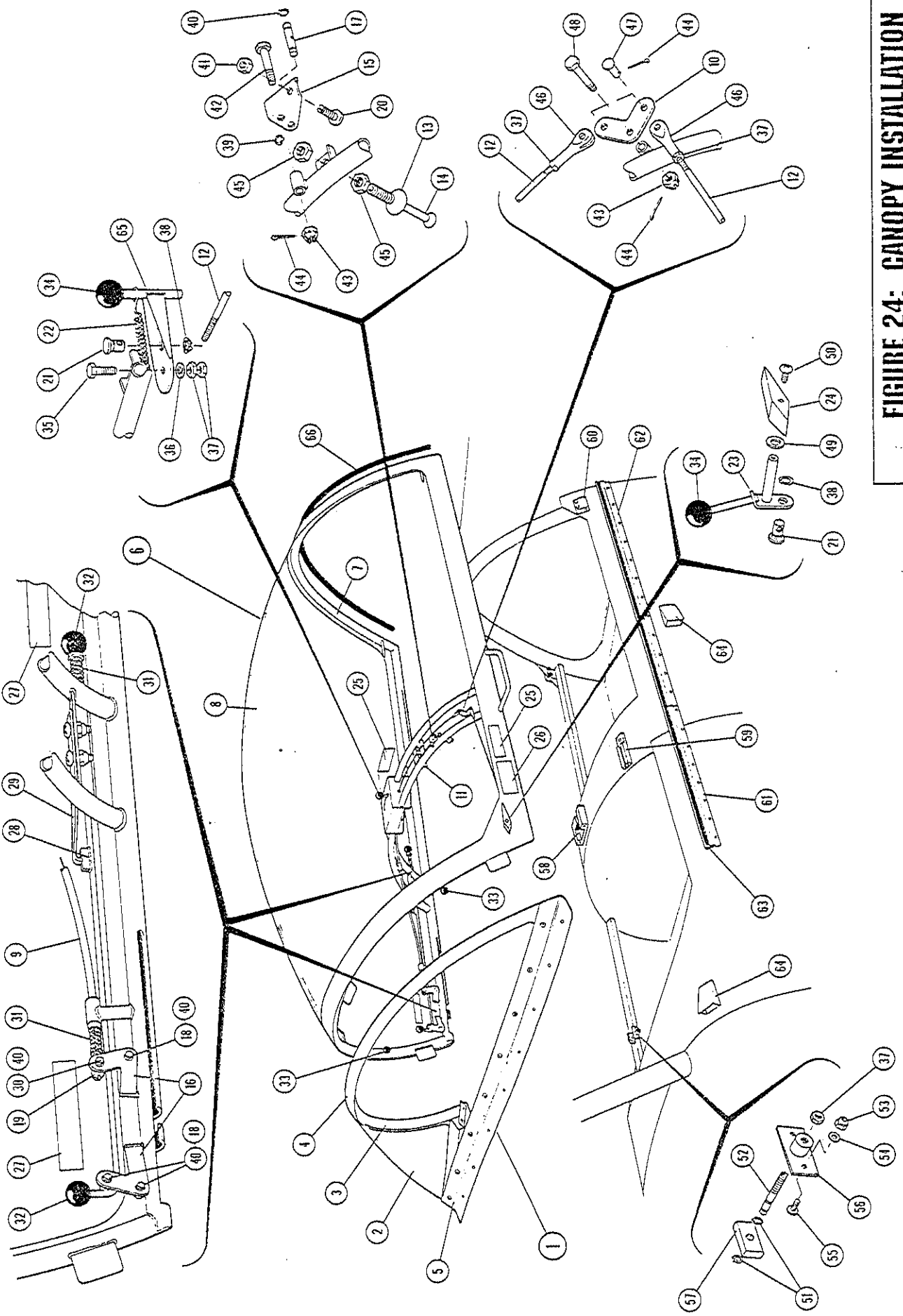

FIGURE 24: CANOPY INSTALLATION

FIGURE 24: CANOPY INSTALLATION

ITEM	PART NUMBER	DESCRIPTION	QTY	SERIAL NO.'S AFFECTED
1	2-8004-001	Windscreen, Canopy	1	
2	2-8006-002	Windscreen	1	
3	2-8002-001	Weldment, Windscreen	1	
4	2-8004-003	Trim, Windscreen	1	
5	2-8004-002	Flange, Windshield	1	
	56631	Screw: AN526-632-R7	11	
	58710	Washer: AN960-6L	11	
	55475	Nut: AN365-632A	11	
6	2-8005-001	Canopy Assembly	1	
7	2-8001-000	Weldment, Canopy Frame	1	
8	2-8006-003	Window, Canopy	1	
9	2-8005-003	Cable, Canopy Stop	1	
10	2-8003-005	Canopy Bellcrank Assembly	1	
11	79839	Shaft Guide, Deirin	1	
12	2-8003-012	Shaft	2	
13	79843	Support Shaft	1	
14	79844	Actuator Shaft	1	
15	2-8003-015	Lever, Actuator	1	
16	2-8003-016	Interlock Lever Assembly	2	
17	79847	Anchor Pin	1	
18	79848	Anchor Pin	3	
19	79850	Spring Cup	2	
20	79851	Actuator Screw	1	
21	79854	Bushing, Cable	2	
22	77847	Latch Spring	1	
23	2-8003-031	Canopy Lever Assembly	1	
24	79866	Latch Knob	1	
25	75042	Placard, Canopy Inside Latch	2	
26	75043	Placard, Canopy Outside Latch	1	
27	75044	Placard, Canopy Jettison	2	
28	2-8008-001	Shaft, Emergency Release	1	
29	2-8008-004	Spring	1	
	56629	Screw: AN526-632-R6	2	
	55475	Nut: AN365-632A	2	
30	79852	Anchor Pin	1	
31	63020	Spring, compression	2	
32	62104	Knob, Canopy (red)	2	
33	62105	Knob, Canopy (black)	2	
34	62106	Knob, Canopy (black)	2	
35	50051	Bolt: AN3-6A	1	
36	58740	Washer: AN960-10	1	
37	54548	Nut: AN315-3R	5	
38	62584	Ring, Retaining	2	
39	62580	Ring, Retaining	1	
40	62586	Ring, Retaining	10	
41	55020	Nut: AN340C-832	1	
42	50150	Bolt: AN3-12	1	
43	54375	Nut: AN310-3	2	
44	55675	Pin, Cotter: AN380-2-2	3	
45	54550	Nut: AN315-4R	2	
46	56940	Terminal, Tie Rod: AN665-21R	2	
47	55975	Pin, Clevis: AN393-11	1	
48	50200	Bolt: AN3-14	1	
49	58760	Washer: AN960-416 (as required)	-	
50	56624	Screw: AN526-632-R4	1	
51	62582	Ring, Retaining	2	

FIGURE 24: CANOPY INSTALLATION

ITEM	PART NUMBER	DESCRIPTION	QTY	SERIAL NO.'S AFFECTED
52	79838	Pin	1	
53	55375	Nut: AN364-832A	1	
54	58730	Washer: AN960-8L	1	
55	56832	Screw: AN526-832-R5	1	
56	2-8003-004	Pin Support Assembly	1	
57	79836	Bearing, Delrin	1	
58	79853	Latch Plate	1	
	2-8003-027	Shim	A/R	
	2-8003-028	Shim	A/R	
	56562	Screw: AN507-832-R12	3	
	58720	Washer: AN960-8	4	
	55550	Nut: AN365-832A	4	
	56568	Screw: AN507-832-R18	1	
59	79869	Slide, Delrin	1	
60	79841	Receptacle, Delrin	2	
	56564	Screw: AN507-832-R14	4	
	58730	Washer: AN960-8L	4	
	55375	Nut: AN364-832A	4	
61	2-8000-005	Strip, Seal Support Forward L H	1	
	2-8000-006	Strip, Seal Support Forward R H	1	
62	2-8000-003	Strip, Seal Support Aft L H	1	
	2-8000-004	Strip, Seal Support Aft R H	1	
63	2-8000-015	Seal, Side	2	
64	1-0104-014	Scoop	4	
65	2-8003-035	Canopy Lever Assembly	1	
66	2-8005-017	Seal, Rear	1	